

# New Technical Notes

Macintosh

®

---

Developer Support

## HW 13 - Macintosh Portable ROM Expansion Hardware

Written by: Dennis Hescox

October 1989

This Technical Note explains the practice of and theory behind compatible use of the expansion ROM in the Macintosh Portable.

---

Due to the unique nature of the Macintosh Portable, developers now have the ability to add ROM to the Macintosh. To provide for compatible shared use of this ROM space with Apple and other developers, this Note describes the feature and suggests methods of shared implementation.

### Address Space

The Macintosh Portable contains 256K of processor ROM, which is fundamentally the same as the ROM in the Macintosh SE. This ROM is located at the low end of a 1 MB ROM space. With an expansion card, one can either completely replace the 1 MB ROM or simply add an additional 4 MB of ROM. The original 1 MB of address space is **reserved** for use by Apple, but the additional 4 MB address space is available for third-party developers.

Apple reserved ROM space is located from \$90 0000 through \$9F FFFF. You can replace this ROM space with an expansion board, thus overriding these ROMs; however, if you override these ROMs your machine will no longer work with most applications. This ability to override the original ROMs is intended for Apple in the event that a ROM upgrade is ever necessary for the Macintosh Portable. Developers should use the 4 MB ROM address space from \$A0 0000 through \$DF FFFF, which is illustrated in Figure 1, for expansion.

Since Apple could provide a ROM upgrade (on a ROM expansion board), we recommend that developers use a standard 32-pin DIP socketed ROM part for any expansion board. Following this recommendation ensures that the user will never have to choose between an Apple ROM upgrade and a third-party expansion board, since Apple could provide sockets for third-party ROMs if we were to produce such an upgrade.

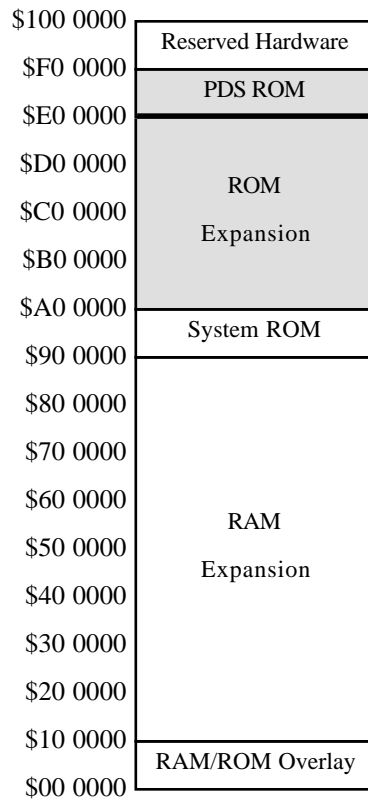
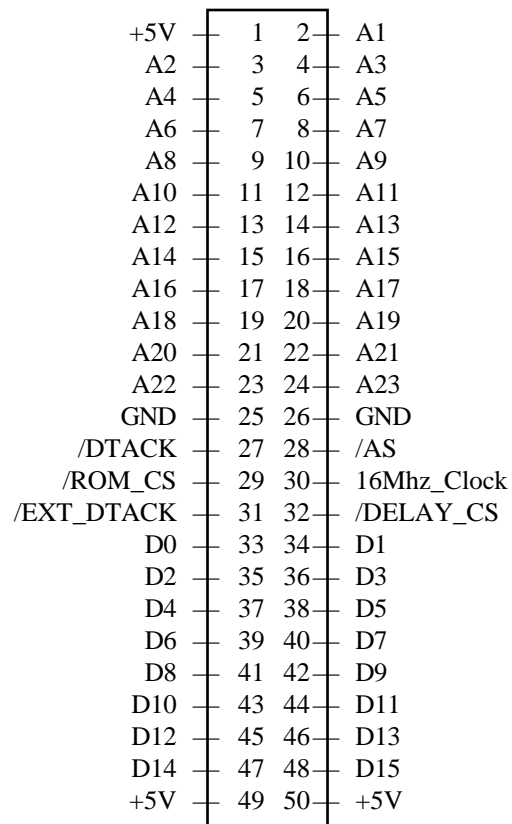

**Figure 1–Macintosh Portable Memory Map**

### Expansion ROM Board

If Apple were to produce an expansion ROM board for an upgrade, it would have the following characteristics. Side one would contain four 32-pin ROM sockets compatible with 128K x 8 bit or 512K x 8 bit ROMs, a dip switch for choosing between 128K or 512K socket address sizes, and appropriate decoupling capacitors. Side two would contain Apple’s expansion ROMs and any additional circuitry. This design implies that developers would be able to use at most either 512K or 2 MB of the total 4 MB expansion space.

When designing your own expansion board, remember that it must contain circuitry for decoding, controlling, and buffering, and it should use CMOS, since the Macintosh Portable restricts ROM expansion boards to a maximum of 25ma. The number of wait states inserted depends upon the DTACK generated by your board, which connects to the Macintosh Portable through a single 50-pin connector (slot). The machine provides all of the appropriate signals (address bus, data bus, and control) to the expansion slot, where they are decoded into chip selects and routed to address and data buffers. These signal names and descriptions are illustrated in Figure 2 and described in Table 1. It is also important to buffer the address and data buffers to reduce capacitive loading.



**Figure 2—Internal ROM Expansion Connector Signals**

<b>Pin Number</b>	<b>Signal Name</b>	<b>Signal Description</b>
1	+5V	Vcc
2-24	A1-23	Unbuffered 68HC000 address signals A1-23
25-26	GND	Logic Ground
27	/DTACK	/DTACK input to 68HC000
28	/AS	68HC000 address strobe signal
29	/ROM_CS	Permanent ROM chip select signal. Selects in range \$90 0000 through \$9F FFFF.
30	16 Mhz_clock	16 Mhz system clock.
31	/EXT_DTACK	External /DTACK signal that disables main system /DTACK
32	/DELAY_CS	This signal is generated by the addressing PAL and is used to put the ROM board into the idle mode by inserting multiple wait states.
33-48	D0-15	68HC000 unbuffered data signals D0-15
49-50	+5V	Vcc

**Table 1—Internal ROM Expansion Connector Signal Descriptions**

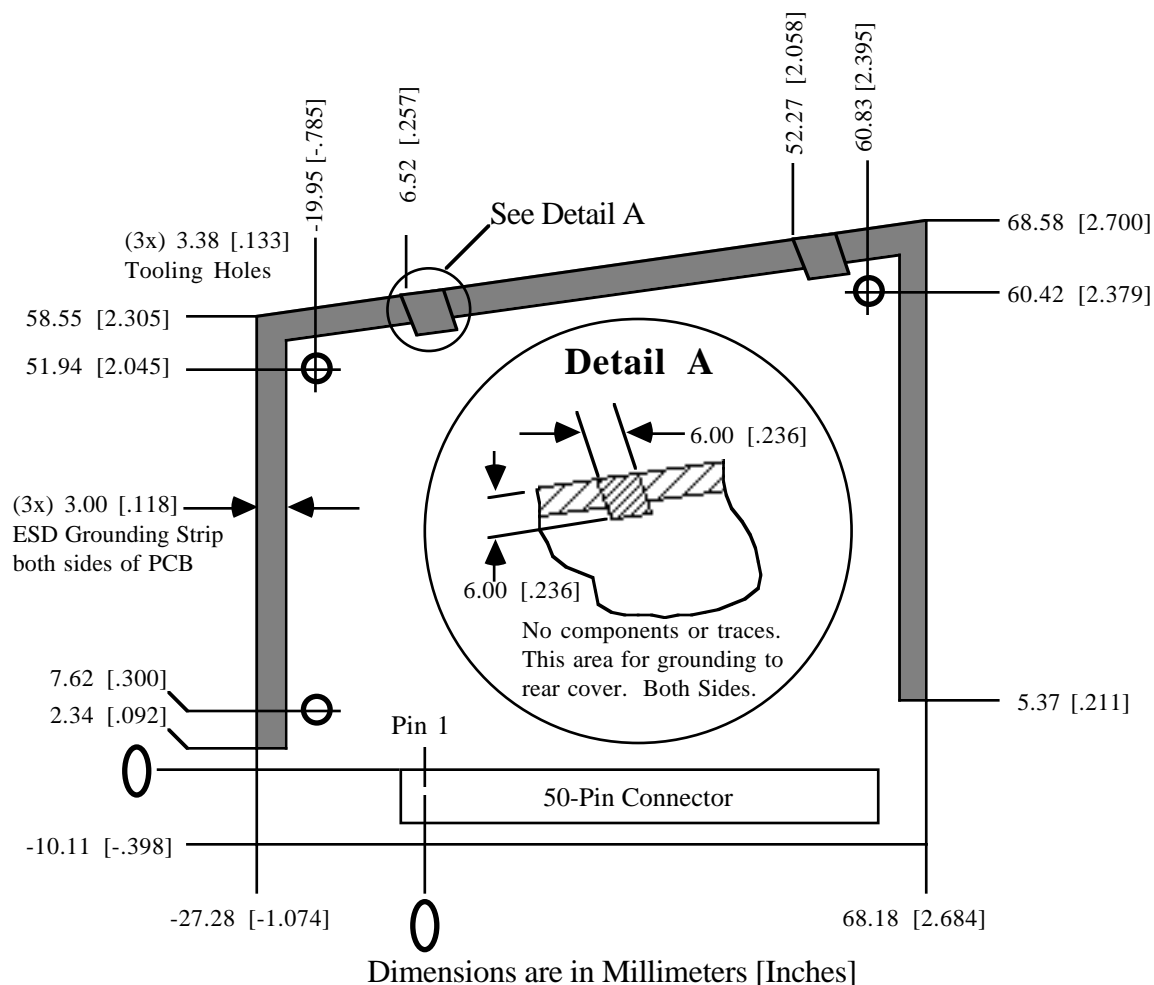

**Figure 3—Internal ROM Expansion Board Guidelines**

## Software Standards

For the purposes of expansion ROM, Apple has introduced Electronic Disks (EDisks), which appear to the user as very fast, silent disk drives. The EDisk driver supports EDisks, which use RAM or ROM as their storage media.

ROM EDisks, which can be produced by third parties, are connected to the system using the internal ROM expansion slot. The 4 MB address space allocated for this type of expansion supports any number of ROM EDisks, as long as they start on a 64K boundary (their size may exceed 64K). ROM EDisks behave like RAM EDisks, except that they are read-only and cannot be resized.

## The EDisk Driver

The EDisk driver provides a system interface to EDisks similar to that provided by the Sony and SCSI disk drivers. It supports 512 byte block I/O operations and does not support file system tags. The EDisk driver is a ROM 'DRVR' resource with an ID of 48, RefNum of -49, and driver name of ".EDisk". Since it is a disk driver, it also creates a Drive Queue Element for each EDisk. Information on how these driver calls apply to the Sony driver appear in the Disk Driver chapters of *Inside Macintosh*, Volumes II, IV, & V.

## EDisk Implementation Details

The remainder of this section describes some of the implementation details, data formats, and algorithms used by the EDisk driver that may be useful for developers who want to produce ROM EDisks.

### Data Checksumming

To provide better data integrity, the EDisk driver supports checksumming of each data block, which is computed when a write is performed to a block and checked on every read operation. It computes a 32-bit checksum for each 512-byte block. This calculation is performed by adding each longword in the block to a running longword checksum, which is initially zero, and is rotated left by one bit before each longword is added. The following assembly code demonstrates this algorithm:

```
Lea      TheBlock,a0    ; A0 is pointer to the block to checksum
Moveq.L  #0,D0          ; D0 is the checksum, initially zero
Moveq.L  #(512/4)-1,D1  ; loop counter for 1 block (4 bytes per
                        ; iteration)
@Loop   Rorl.L   #1,D0    ; rotate the checksum
        Add.L   (A0)+,D0  ; add the data to the running checksum
        Dbra   D1,@Loop  ; loop through each longword in the block
```

### Internal ROM EDisk Details

When the EDisk driver is opened, it searches the address range from the base of the system ROM to \$00E0 0000 for internal ROM EDisks. An internal ROM EDisk must begin with an EDisk header block, which must start on a 64K boundary (but may be any size). If a valid header block is found, it is compared to all other known headers, and if it is identical to another, it is ignored to eliminate duplicates caused by address wrapping. If the header block is unique, the EDisk driver supports it and creates a drive queue entry for it. The driver can support any number of internal ROM EDisks, and it is limited only by the address space allocated for ROM.

### EDisk Header Format

There is a 512-byte header block associated with ROM EDisks. This header describes the layout of the EDisk and uniquely identifies it. The general format of the header block is described below. The EDisk header marks the beginning of an EDisk, and it should occur at the beginning of the ROM space that is used for EDisk storage (i.e., starting at the first byte of a 64K ROM block).

EDiskHeader	Record 0,increment			; layout of the EDisk signature block
HdrScratch	DS.B	128		; scratch space for r/w testing and vendor info
HdrBlockSize	DS.W	1		; size of header block (512 bytes for version 1)
HdrVersion	DS.W	1		; header version number (this is version 1)
HdrSignature	DS.B	12		; 45 44 69 73 6B 20 47 61 72 79 20 44
HdrDeviceSize	DS.L	1		; size of device, in bytes
HdrFormatTime	DS.L	1		; time when last formatted (pseudo unique ID)
HdrFormatTicks	DS.L	1		; ticks when last formatted (pseudo unique ID)
HdrChecksumOff	DS.L	1		; offset to the Checksum table, if present
HdrDataStartOff	DS.L	1		; offset to the first byte of data storage
HdrDataEndOff	DS.L	1		; offset to the last byte+1 of data storage
HdrMediaIconOff	DS.L	1		; offset to the media Icon and Mask, if present
HdrDriveIconOff	DS.L	1		; offset to the drive Icon and Mask, if present
HdrWhereStrOff	DS.L	1		; offset to the Get Info Where: string, if present
HdrDriveInfo	DS.L	1		; longword for Return Drive Info call, if present
	DS.B	512-*		; rest of block is reserved
EDiskHeaderSize	EQU	*		; size of EDisk header block
	ENDR			

**HdrScratch** is a 128-byte field that is used for read and write testing on RAM EDisks to determine if the memory is ROM or RAM. On ROM EDisks, it should be filled in by the vendor with a unique string to identify this version of the ROM EDisk (e.g., "Copyright 1989, Apple Computer, Inc. System Tools 6.0.4 9/5/89").

**HdrBlockSize** is a 2-byte field that indicates the size of the EDisk header block. The size is currently 512 bytes.

**HdrVersion** is a 2-byte field that indicates the version of the EDisk header block. The version number is currently \$0001.

**HdrSignature** is a 12-byte field that identifies a valid EDisk header block. The signature must be set to 45 44 69 73 6B 20 47 61 72 79 20 44 in hexadecimal.

**HdrDeviceSize** is a 4-byte field that indicates the size of the device in bytes, which may be greater than the actual usable storage space. One might also think of the device size as the offset (from the beginning of the header block) of the last byte of the storage device.

**HdrFormatTime** is a 4-byte field that indicates the time of day when the EDisk was last formatted. The EDisk driver updates this for RAM EDisks when the format control call is made. This information may be useful for uniquely identifying a RAM EDisk.

**HdrFormatTicks** is a 4-byte field that indicates the value of the system global `Ticks` when the EDisk was last formatted, which should be a unique number. The EDisk driver updates this for RAM EDisks when the format control call is made. This information may be useful for uniquely identifying a RAM EDisk.

HdrCheckSumOff	is a 4-byte field that is the offset (from the beginning of the header block) of the checksum table, or zero if checksumming should not be performed on this EDisk.
HdrDataStartOff	is a 4-byte field that is the offset (from the beginning of the header block) of the first block of EDisk data.
HdrDataEndOff	is a 4-byte field that is the offset (from the beginning of the header block) of the byte after the end of the last block of EDisk data.
HdrMediaIconOff	is a 4-byte field that is the offset (from the beginning of the header block) of the 128-byte icon and 128-byte icon mask, which represents the disk media. An offset of zero indicates that the EDisk driver should use the default media icon for this EDisk.
HdrDriveIconOff	is a 4-byte field that is the offset (from the beginning of the header block) of the 128-byte icon and 128-byte icon mask, which represents the disk drive physical location. An offset of zero indicates that the EDisk driver should use the default drive icon for this EDisk.
HdrWhereStrOff	is a 4-byte field that is the offset (from the beginning of the header block) of the Pascal string that describes the disk location for the Finder Get Info command. An offset of zero indicates that the EDisk driver should use the default string for this EDisk.
HdrDriveInfo	is a 4-byte field that should be returned by the drive information control call. A value of zero indicates that the EDisk driver should use the default drive info for this EDisk.

You should not override the default media or drive icons without first giving serious consideration as to how a different icon will affect the user interface. What often appears to be a clever idea for a cute icon usually turns out to be a source of frustration for the user when deciding what the item is and where it is physically located.

## Some Final Thoughts

### Do Not Use More Space Than You Need

As wonderful and indispensable as your ROM product may be, users may wish to also use ROMs from another developer. Although ROM address space is quite large (in today's terms), board space and number of ROM chip sockets is limited. If you use only the space you really need and leave room (address space and empty chip sockets) in your ROM product to add other ROMs, users will never have to make a choice between your product and another, unanticipated stroke of genius.



## **Keep It Relocatable**

Just because your code is in ROM does not mean that it will always reside at a specific address. When moving your ROM to another board (an Apple upgrade or another third-party board), users should neither have to worry about address range conflicts nor socket location. In addition, Apple may implement ROM expansion in a future product with expanded or different address space; keeping your ROM code relocatable could mean the difference between additional sales or incompatibility and upgrades.

### **Further Reference:**

- 
- *Inside Macintosh*, Volume II, IV, & V, The Disk Driver