

Developer Note

PowerBook 1400 Computer

PowerBook 1400 c
PowerBook 1400 cs

Developer Note

© Apple Computer, Inc. 1995, 1996

Apple Computer, Inc.
© 1996 Apple Computer, Inc.
All rights reserved.

No part of this publication may be reproduced, stored in a retrieval system, or transmitted, in any form or by any means, mechanical, electronic, photocopying, recording, or otherwise, without prior written permission of Apple Computer, Inc., except to make a backup copy of any documentation provided on CD-ROM. Printed in the United States of America.

The Apple logo is a trademark of Apple Computer, Inc. Use of the "keyboard" Apple logo (Option-Shift-K) for commercial purposes without the prior written consent of Apple may constitute trademark infringement and unfair competition in violation of federal and state laws.

No licenses, express or implied, are granted with respect to any of the technology described in this book. Apple retains all intellectual property rights associated with the technology described in this book. This book is intended to assist application developers to develop applications only for Apple-labeled or Apple-licensed computers.

Every effort has been made to ensure that the information in this manual is accurate. Apple is not responsible for printing or clerical errors.

Apple Computer, Inc.
1 Infinite Loop
Cupertino, CA 95014
408-996-1010

Apple, the Apple logo, AppleLink, Apple SuperDrive, AppleTalk, LaserWriter, LocalTalk, MacTCP, Macintosh, PowerBook, and Power Macintosh are trademarks of Apple Computer, Inc., registered in the United States and other countries.

Finder, Mac, and QuickDraw are trademarks of Apple Computer, Inc. Adobe, Adobe Photoshop, and PostScript are trademarks of Adobe Systems Incorporated, which may be registered in certain jurisdictions.

DECnet is a trademark of Digital Equipment Corporation.

Helvetica and Palatino are registered trademarks of Linotype Company.

ITC Zapf Dingbats is a registered trademark of International Typeface Corporation.

NuBus is a trademark of Texas Instruments.

PowerPC is a trademark of International Business Machines

Corporation, used under license therefrom.

SoftWindows is a trademark used under license by Insignia from Microsoft Corporation.

UNIX is a registered trademark of Novell, Inc. in the United States and other countries, licensed exclusively through X/Open Company, Ltd.

Simultaneously published in the United States and Canada.

LIMITED WARRANTY ON MEDIA AND REPLACEMENT

If you discover physical defects in the manual or in the media on which a software product is distributed, ADC will replace the media or manual at no charge to you provided you return the item to be replaced with proof of purchase to ADC.

ALL IMPLIED WARRANTIES ON THIS MANUAL, INCLUDING IMPLIED WARRANTIES OF MERCHANTABILITY AND FITNESS FOR A PARTICULAR PURPOSE, ARE LIMITED IN DURATION TO NINETY (90) DAYS FROM THE DATE OF THE ORIGINAL RETAIL PURCHASE OF THIS PRODUCT.

Even though Apple has reviewed this manual, APPLE MAKES NO WARRANTY OR REPRESENTATION, EITHER EXPRESS OR IMPLIED, WITH RESPECT TO THIS MANUAL, ITS QUALITY, ACCURACY, MERCHANTABILITY, OR FITNESS FOR A PARTICULAR PURPOSE. AS A RESULT, THIS MANUAL IS SOLD "AS IS," AND YOU, THE PURCHASER, ARE ASSUMING THE ENTIRE RISK AS TO ITS QUALITY AND ACCURACY.

IN NO EVENT WILL APPLE BE LIABLE FOR DIRECT, INDIRECT, SPECIAL, INCIDENTAL, OR CONSEQUENTIAL DAMAGES RESULTING FROM ANY DEFECT OR INACCURACY IN THIS MANUAL, even if advised of the possibility of such damages.

THE WARRANTY AND REMEDIES SET FORTH ABOVE ARE EXCLUSIVE AND IN LIEU OF ALL OTHERS, ORAL OR WRITTEN, EXPRESS OR IMPLIED. No Apple dealer, agent, or employee is authorized to make any modification, extension, or addition to this warranty.

Some states do not allow the exclusion or limitation of implied warranties or liability for incidental or consequential damages, so the above limitation or exclusion may not apply to you. This warranty gives you specific legal rights, and you may also have other rights which vary from state to state.

Contents

Figures and Tables vii

Preface **About This Developer Note** ix

Contents of This Note ix
Supplemental Reference Documents x
 Apple Publications x
 Other Publications xi
Conventions and Abbreviations xi
 Typographical Conventions xi
 Standard Abbreviations xii

Chapter 1 **Introduction** 1

Features 2
 New Features 2
 Modified Features 2
 Unchanged Features 3
Appearance 4
Configurations 5
Peripheral Devices 6

Chapter 2 **Architecture** 7

Devices on the Processor Bus 8
 Main Processor 8
 RAM 9
 ROM 10
 PBX Memory Controller IC 10
 Memory Control 10
 Bus Bridge 10
Devices on the I/O Bus 10
 Whitney Peripheral Support IC 11
 Combo IC 12
 Singer IC 12
 Power Manager IC 12
 Display Controller IC 12
 Video Card Connector 12

Baboon Custom IC	13
Floppy Disk Controller IC	13
TREX Custom IC	13

Chapter 3 **I/O Features** 15

Internal IDE Hard Disk Drive	16
Hard Disk Specifications	16
Hard Disk Connector	17
Signal Assignments	18
IDE Signal Descriptions	19
Trackpad	20
Keyboard	20
Flat Panel Display	22
Flat Panel Display Circuitry	22
Number of Colors	22
Serial Port	23
SCSI Port	23
ADB Port	24
Infrared Link	25
Sound System	26
Sound Inputs	26
Sound Outputs	27

Chapter 4 **Expansion Modules** 29

Expansion Bay	30
Expansion Bay Module for Floppy Disk	30
Expansion Bay Module for CD-ROM	32
Expansion Bay Connectors	34
Signals on the Floppy Disk Connector	34
Signals on the CD-ROM Connector	36
Unused Signals	39
User Installation of an Expansion Bay Module	39
Sequence of Control Signals	39
Guidelines for Developers	40
RAM Expansion Cards	40
Electrical Design Guidelines for the RAM Expansion Cards	41
Connector Pin Assignments	41
Signal Descriptions	43
Address Multiplexing	44
RAM Banks	46
RAM Bank Selection	46
DRAM Device Requirements	47

RAM Expansion Card Electrical Limits	48
Mechanical Design of the RAM Expansion Cards	49
Design of the User-Installed RAM Card	49
Design of the Factory-Installed RAM Expansion Card	50
RAM Card Connectors	52
Expansion Card and Connector	52
Expansion Card Connector	52
Signals on the Expansion Card Connector	52
Expansion Card Mechanical Design	54
PC Card Slot	57
PC Card Features	58
Summary Specifications	58
Access Windows	58
Data Access	59
Signal Definitions	59
Power	59
Controller Interrupts	60

Chapter 5

Software Features 61

ROM Software	62
Machine Identification	62
Larger Flat Panel Displays	62
System Software	62
Modified Software Components	63
Apple Guide	63
Apple Menu Options	63
CloseView	63
Enabler	63
File Sharing	64
Finder	64
Find File	64
General Controls Control Panel	64
Memory Control Panel	64
Monitors & Sound	65
Native Resource Manager	65
Open Transport	65
SimpleText	65
Consolidation of Files	65
Open Transport	66
New Features of Open Transport	67
Compatibility	67

Glossary 69

Index 71

Figures and Tables

Chapter 1	Introduction	1
	Figure 1-1	Front view of the computer 4
	Figure 1-2	Rear view of the computer 5
	Table 1-1	Configurations 5
Chapter 2	Architecture	7
	Figure 2-1	Block diagram 9
Chapter 3	I/O Features	15
	Figure 3-1	Maximum dimensions of the internal IDE hard disk 17
	Figure 3-2	Connector for the internal IDE hard disk 18
	Figure 3-3	Keyboard, U.S. layout 21
	Figure 3-4	Keyboard, ISO layout 21
	Figure 3-5	Serial port connector 23
	Figure 3-6	ADB connector 25
	Table 3-1	Signal assignments on the IDE hard disk connector 18
	Table 3-2	Signals on the IDE hard disk connector 19
	Table 3-3	Characteristics of the displays 22
	Table 3-4	Serial port signals 23
	Table 3-5	SCSI connector signals 24
	Table 3-6	ADB connector pin assignments 25
Chapter 4	Expansion Modules	29
	Figure 4-1	Side view of a floppy disk module 30
	Figure 4-2	Top view of a floppy disk module 31
	Figure 4-3	Bottom view of a floppy disk module 32
	Figure 4-4	Top view of a CD-ROM module 33
	Figure 4-5	Bottom view of a CD-ROM module 34
	Figure 4-6	User-installed RAM expansion card 50
	Figure 4-7	Factory-installed RAM card 51
	Figure 4-8	Height limits on the connector side 51
	Figure 4-9	Component side of the expansion card 55
	Figure 4-10	Trace side of the expansion card 55
	Figure 4-11	Height restrictions on the component side 56
	Figure 4-12	Height restrictions on the trace side 57
	Table 4-1	Connectors for expansion bay modules 34
	Table 4-2	Signal assignments on the floppy disk connector 35

Table 4-3	Signals on the floppy disk connector	35	
Table 4-4	Signal assignments on the CD-ROM connector	36	
Table 4-5	Signal assignments for a hard disk drive	37	
Table 4-6	Signals on the CD-ROM connector	38	
Table 4-7	Unused IDE signals	39	
Table 4-8	Signals on the RAM expansion connectors	41	
Table 4-9	Descriptions of signals on the RAM expansion connector	43	
Table 4-10	Address multiplexing for some typical DRAM devices	45	
Table 4-11	Configurations of RAM banks	46	
Table 4-12	RAM bank selection	46	
Table 4-13	Bank selection signal connections	47	
Table 4-14	Signals on the expansion card connector	52	
Table 4-15	Descriptions of the signals on the expansion card connector	54	

About This Developer Note

This developer note is a concise description of the Macintosh PowerBook 1400 computer, with emphasis on the features that are new or different from those of earlier Macintosh PowerBook computers.

This developer note is intended to help hardware and software developers design products that are compatible with the Macintosh products described in the note. If you are not already familiar with Macintosh computers or if you would simply like more technical information, you may wish to read the supplementary reference documents described in this preface.

This note is published in two forms: a paper version and an online version. The paper version is available through the *Apple Developer Catalog* (ADC). For information about ADC, see “Supplemental Reference Documents,” later in this preface.

You can obtain the online version in two ways:

- on the Internet, under the heading Developer Notes at <http://www.devworld.apple.com/dev/techsupport.shtml>
- on the Reference Library Edition of the Developer CD Series, available through the *Apple Developer Catalog*.

Contents of This Note

The information in this note is arranged in five chapters.

- Chapter 1, “Introduction,” introduces the PowerBook 1400 computer and describes its new features.
- Chapter 2, “Architecture,” describes the internal logic of the computer, including the main ICs that appear in the block diagram.
- Chapter 3, “I/O Features,” describes the input/output features, including both the internal I/O devices and the external I/O ports.
- Chapter 4, “Expansion Modules,” describes the expansion features of interest to developers. It includes development guides for expansion bay devices, the RAM expansion card, the expansion card, and the PC card slot.
- Chapter 5, “Software Features,” describes the new features of the ROM and system software, with the emphasis on software that is specific to this computer.

This developer note also contains a glossary and an index.

Supplemental Reference Documents

The following documents provide information that complements or extends the information in this developer note.

Apple Publications

To see how the PowerBook 1400 computer is similar to the Macintosh PowerBook 5300 computer, developers should have copies of *Macintosh Developer Note Number 14*. The developer note is available on the Developer CD series and through ADC.

For information about PC cards and the PCMCIA slot, developers should have a copy of *PC Card Expansion for PowerBook Computers*. Developers should also have copies of the appropriate Apple reference books, including the relevant volumes of *Inside Macintosh*. These Apple books are available in technical bookstores and through ADC.

The *Apple Developer Catalog* (ADC) is Apple Computer's worldwide source for hundreds of development tools, technical resources, training products, and information for anyone interested in developing applications on Apple computer platforms. Customers receive the *Apple Developer Catalog* featuring all current versions of Apple development tools and the most popular third-party development tools. ADC offers convenient payment and shipping options, including site licensing.

To order products or to request a complimentary copy of the *Apple Developer Catalog*, contact

Apple Developer Catalog
 Apple Computer, Inc.
 P.O. Box 319
 Buffalo, NY 14207-0319

Telephone	1-800-282-2732 (United States) 1-800-637-0029 (Canada) 716-871-6555 (International)
Fax	716-871-6511
AppleLink	ORDER.ADC
Internet	order.adc@applelink.apple.com

Other Publications

For information about programming the PowerPC™ family of microprocessors, developers should have copies of Motorola's *PowerPC 601 RISC Microprocessor User's Manual* and *PowerPC 603e Microprocessor Implementation Definition Book IV*.

For information about ATA devices such as the built-in IDE hard disk, developers should have access to the following ANSI specifications:

- ATA/IDE specification, ANSI proposal X3T10/0948D, Revision 2K or later (ATA-2)
- ATAPI specification, ANSI proposal X3T13/1153D AT Attachment-4 with Packet Interface Extension, Revision 2 (ATA/ATAPI-4)

For information about the sound codec used in the custom sound IC, developers should refer to the IT&T ASCO *2300 Audio-Stereo Code Specification*.

For information about PC cards and the PCMCIA slot, developers should refer to the *PCMCIA PC Card Standard*, Release 2.1. You can order that book from

Personal Computer Memory Card International Association
 1030G East Duane Avenue
 Sunnyvale, CA 94086
 Phone: 408-720-0107
 Fax: 408-720-9416

Conventions and Abbreviations

This developer note uses the following typographical conventions and abbreviations.

Typographical Conventions

Computer-language text—any text that is literally the same as it appears in computer input or output—appears in *Courier* font.

Hexadecimal numbers are preceded by a dollar sign (\$). For example, the hexadecimal equivalent of decimal 16 is written as \$10.

Note

A note like this contains information that is of interest but is not essential for an understanding of the text. ◆

IMPORTANT

A note like this contains important information that you should read before proceeding. ▲

Sidebar

Sidebars are used for information that is not part of the main discussion. A sidebar may contain information

about a related subject or technical details that are not required reading.

▲ WARNING

Warnings like this direct your attention to something that could cause injury to the user, damage to either hardware or software, or loss of data. ▲

Standard Abbreviations

Standard units of measure used in this note include

A	amperes	MHz	megahertz
dB	decibels	mm	millimeters
GB	gigabytes	ms	milliseconds
Hz	hertz	mV	millivolts
K	1024	μF	microfarads
KB	kilobytes	ns	nanoseconds
kbps	kilobits per second	Ω	ohms
kHz	kilohertz	pF	picofarads
kΩ	kilohms	V	volts
M	1,048,576	VAC	volts alternating current
mA	milliamperes	VDC	volts direct current
MB	megabytes	W	watts

Other abbreviations used in this note include

$\$n$	hexadecimal value n
AC	alternating current
ADB	Apple Desktop Bus
API	application programming interface
ASIC	application-specific integrated circuit
ATA	AT attachment
ATAPI	ATA packet interface
AUI	auxiliary unit interface
BCD	binary coded decimal
CAS	column address strobe (a memory control signal)
CCFL	cold cathode fluorescent lamp
CD	compact disc

P R E F A C E

CD-ROM	compact-disc read-only memory
CIS	card information structure
CLUT	color lookup table
CMOS	complementary metal oxide semiconductor
CPU	central processing unit
CSC	color screen controller
DAA	data access adapter (a telephone line interface)
DAC	digital-to-analog converter
DC	direct current
DCE	device control entry (a data structure)
DDM	driver descriptor map
DOS	Disk Operating System
DRAM	dynamic RAM
DSP	digital signal processor
FIFO	first in, first out
FPU	floating-point unit
FSTN	film supertwist nematic (a type of LCD)
HBA	host bus adapter
IC	integrated circuit
IDE	integrated device electronics
I/O	input/output
IR	infrared
LCD	liquid crystal display
LS TTL	low-power Schottky TTL (a standard type of device)
MMU	memory management unit
NiCad	nickel cadmium
NiMH	nickel metal hydride
PCMCIA	Personal Computer Memory Card International Association
PDS	processor-direct slot
PROM	programmable read-only memory
PWM	pulse width modulation
RAM	random-access memory
RAMDAC	random-access memory, digital-to-analog converter
RAS	row address strobe
RGB	red-green-blue (a type of color video system)
RISC	reduced instruction set computing
rms	root mean square
ROM	read-only memory

P R E F A C E

SCC	Serial Communications Controller
SCSI	Small Computer System Interface
SNR	signal-to-noise ratio
SOJ	small outline J-lead package
SOP	small outline package
SRAM	static RAM
SVGA	super video graphics adapter
TDM	time-division multiplexing
TFT	thin-film transistor (a type of LCD)
TSOP	thin small outline package
TTL	transistor-transistor logic (a standard type of device)
VCC	positive supply voltage (voltage for collectors)
VGA	video graphics adapter
VRAM	video RAM

Introduction

Introduction

The PowerBook 1400 computer is an all-in-one notebook computer based on the PowerBook 5300 computer but with improved capabilities and an all-new case design. The PowerBook 1400 computer has a PC card slot, an expansion bay, an internal expansion slot, an infrared link, and space for a rechargeable battery.

Features

Many of the features of the PowerBook 1400 computer are similar to those of the Macintosh 5300 computer. The features that are different are listed first; all the features are described later in this developer note.

New Features

Here is a list of the new features of the PowerBook 1400 computer.

- **Case design:** The PowerBook 1400 computer has a new case design. The display assembly includes a panel that the user can remove or replace to personalize the computer.
- **CD-ROM drive:** The computer can accommodate a 5.25-inch CD-ROM drive in its expansion bay. Some configurations include a Macintosh 6x-speed CD-ROM drive.
- **Internal expansion:** The computer has an internal slot that supports an expansion card.

Modified Features

Here is a list of the features of the Macintosh PowerBook 1400 computer that are different from the features of the Macintosh PowerBook 5300.

- **Processor:** The PowerBook 1400 computer has a PowerPC™ 603e microprocessor running at a clock frequency of 117 MHz.
- **RAM:** The computer comes with 12 or 16 MB of low-power, self-refreshing dynamic RAM (DRAM).
- **RAM expansion:** The computer can accept two RAM expansion cards with up to 24 MB each, for a total of up to 64 MB of RAM.
- **Hard disk:** The computer has one internal 2.5-inch IDE hard disk drive with a storage capacity of 750 MB or 1 GB.
- **Display:** The computer has a 11.3 inch color display with SVGA resolution (800 by 600 pixels). The display is backlit by a cold cathode fluorescent lamp (CCFL).
- **Video output:** The video output card is optional.
- **Expansion bay:** The computer has an opening that accepts a plug-in module with a 5.25-inch CD-ROM drive, a 1.4 MB DOS-compatible floppy disk drive, or some other IDE storage device.

Introduction

- **Networking:** The computer has a built-in LocalTalk network interface. An optional Ethernet card can be installed in the internal expansion slot or in a PC card slot.
- **Trackpad:** The integrated flat pad includes tap/double tap and drag. It is similar to the trackpad in the Macintosh PowerBook 190 computer.
- **Weight:** The computer weighs 6.5 pounds with the battery and a floppy disk drive installed.
- **Size:** The computer is 11 inches wide, 9 inches deep, and 2 inches high.
- **Security connector:** The computer has a Kensington Security Connector on the back panel that allows users to attach a security device.

Unchanged Features

Here is a list of the features that are the same as those of the PowerBook 5300. For the sake of completeness, these features are described in the later chapters of this developer note.

- **Disk mode:** With an optional HDI-30 SCSI Disk Adapter cable, the computer allows the user to read and store data on the computer's internal hard disk from another Macintosh computer.
- **Floppy disk:** The computer comes with a 1.4 MB floppy disk drive in the expansion bay.
- **PC card slot:** The computer accepts one type III or two type II PC cards.
- **Modem:** The computer accepts a PC card modem.
- **Standard I/O ports:** The computer has all the standard Macintosh inputs and outputs. The I/O ports are an HDI-30 connector for external SCSI devices, a 4-pin mini-DIN Apple Desktop Bus (ADB) port, an 8-pin mini-DIN serial port, stereo audio input and output jacks, and a video output connector (video support is optional).
- **Sound:** The computer has a built-in microphone and speaker as well as a line-level input jack and a stereo headphone jack.
- **Keyboard:** The keyboard design provides 76 (United States) or 77 (ISO) keys, including 12 function keys.
- **Infrared link:** The computer has an infrared module that can communicate with other IR-equipped PowerBook computers at speeds up to 230 KB per second.
- **Batteries:** The computer has space for one Macintosh PowerBook Rechargeable Battery. The battery is an improved NiMH type with a capacity of 30 watt-hours. It can operate the computer for up to five hours.
- **Power supply:** The computer comes with an external recharger/power adapter that accepts any worldwide standard voltage from 100 to 240 volts AC at 50 to 60 Hz.

Note

The power adapter for the PowerBook 1400 looks a lot like the one for the PowerBook 5300, but it is not the same. Among other things, the connectors are different.

Appearance

The PowerBook 1400 computer has an all-new streamlined case with more flexibility than earlier PowerBook models. Figure 1-1 shows a front view of the computer in the open position. Figure 1-2 shows a rear view of the computer.

Figure 1-1 Front view of the computer

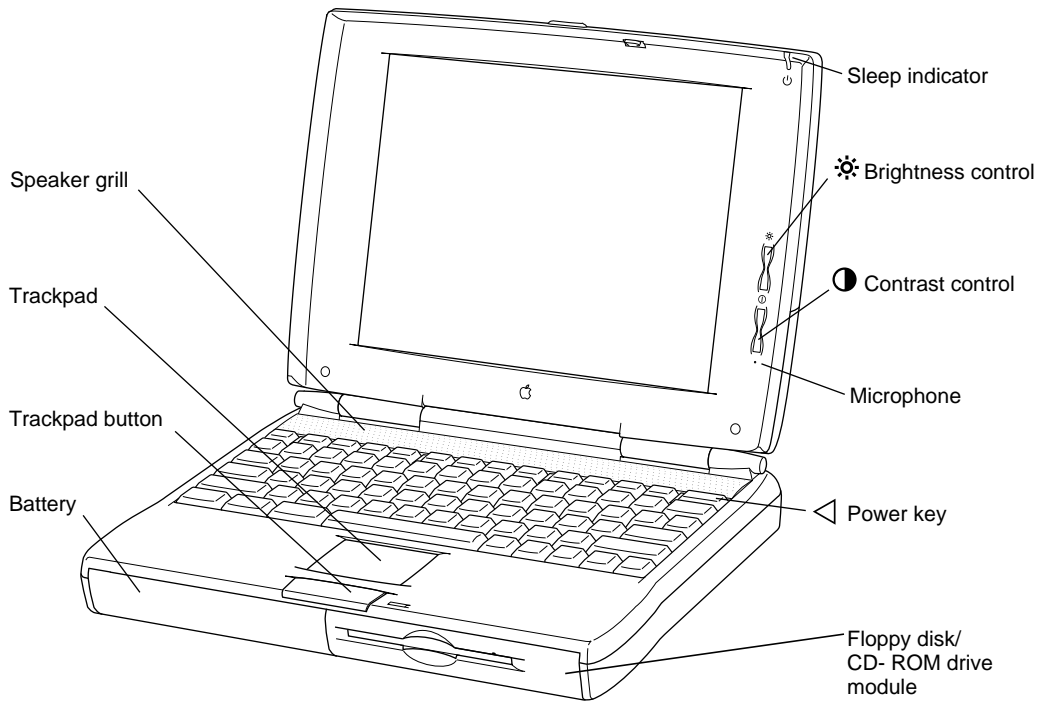
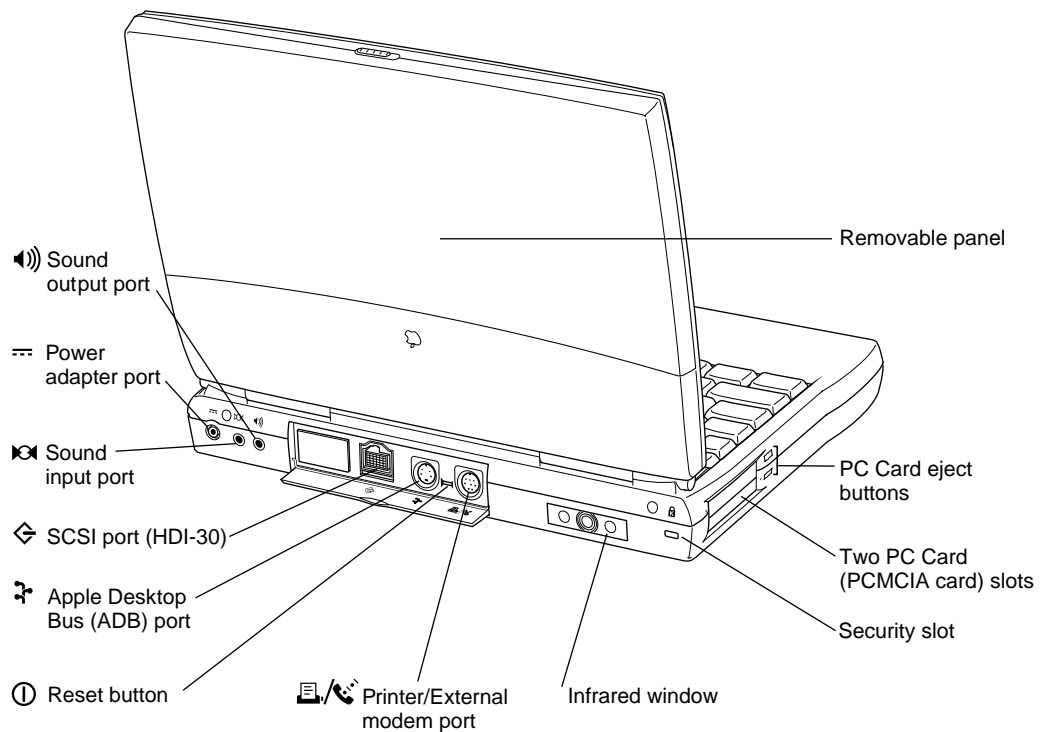

Figure 1-2 Rear view of the computer

Configurations

The Macintosh PowerBook 1400 computer is available in three configurations, as shown in Table 1-1.

Table 1-1 Configurations

Model number	RAM size	Hard disk size	Display size (pixels)	Display type	CD-ROM drive?
PowerBook 1400 cs	12 MB	750 MB	800 by 600	DualScan color	No
PowerBook 1400 cs	16 MB	750 MB	800 by 600	DualScan color	Yes
PowerBook 1400 c	16 MB	1 GB	800 by 600	Active-matrix color	Yes

Introduction

Note

The 12 MB configuration has 8 MB of RAM on the main logic board and an additional 4 MB on a factory-installed RAM expansion card. The 16 MB configuration has 8 MB on the factory-installed RAM expansion card. That card is in addition to the user-accessible RAM expansion cards. For more information, see “RAM Expansion Cards” beginning on page 40. ♦

Peripheral Devices

In addition to the devices that are included with the computer, several peripheral devices are available separately:

- The Macintosh PowerBook 8 MB Memory Expansion Kit for the PowerBook 1400 computer expands the RAM to 20 or 24 MB.
- The optional video output card can be installed in the internal expansion slot. The card is similar to the one used in the Macintosh PowerBook 5300. The video card supports video monitors with up to 624 by 832 pixels at 8 bits per pixel.
- The Macintosh 6x-speed CD-ROM drive fits into the expansion bay.
- The Macintosh PowerBook Rechargeable Battery is available separately as an additional or replacement battery.
- The Macintosh PowerBook 45W AC Adapter, which comes with the computer, is also available separately. The adapter can recharge the internal battery in just four hours while the computer is running or two hours while the computer is shut down or in sleep mode.

Architecture

Architecture

The architecture of the PowerBook 1400 computer is designed around two buses: the processor bus and the I/O bus. The processor and memory are connected to the processor bus, which operates at 33.33 MHz. The input and output devices are connected to the I/O bus, a 68030-compatible bus that operates at 25.175 MHz. An Apple custom IC called the PBX IC acts as the bridge between the two buses, translating processor bus cycles into single or multiple I/O bus cycles, as needed. The block diagram in Figure 2-1 shows the buses and the devices that are connected to them.

Note

Except for the floppy disk controller IC, the architecture of the PowerBook 1400 computer is similar to that of the Macintosh PowerBook 5300 computer. ♦

Devices on the Processor Bus

The processor bus connects the PowerPC 603e microprocessor, the main RAM, and the ROM. Optional RAM expansion cards can be plugged into the logic board and are also connected to the processor bus.

Main Processor

The main processor in the PowerBook 1400 computer is a PowerPC 603e microprocessor, an enhanced version of the PowerPC 603. Its principal features include

- full RISC processing architecture
- a load-store unit that operates in parallel with the processing units
- a branch manager that can usually implement branches by reloading the incoming instruction queue without using any processing time
- two internal memory management units (MMUs), one for instructions and one for data
- two 16 KB on-chip caches for data and instructions

For technical details, please refer to the reference books listed in the preface.

The PowerPC 603e microprocessor in the PowerBook 1400 computer runs at a clock speed of 116.67 MHz. The microprocessor's clock speed is locked at 3.5 times the processor bus's clock speed, which is 33.33 MHz.

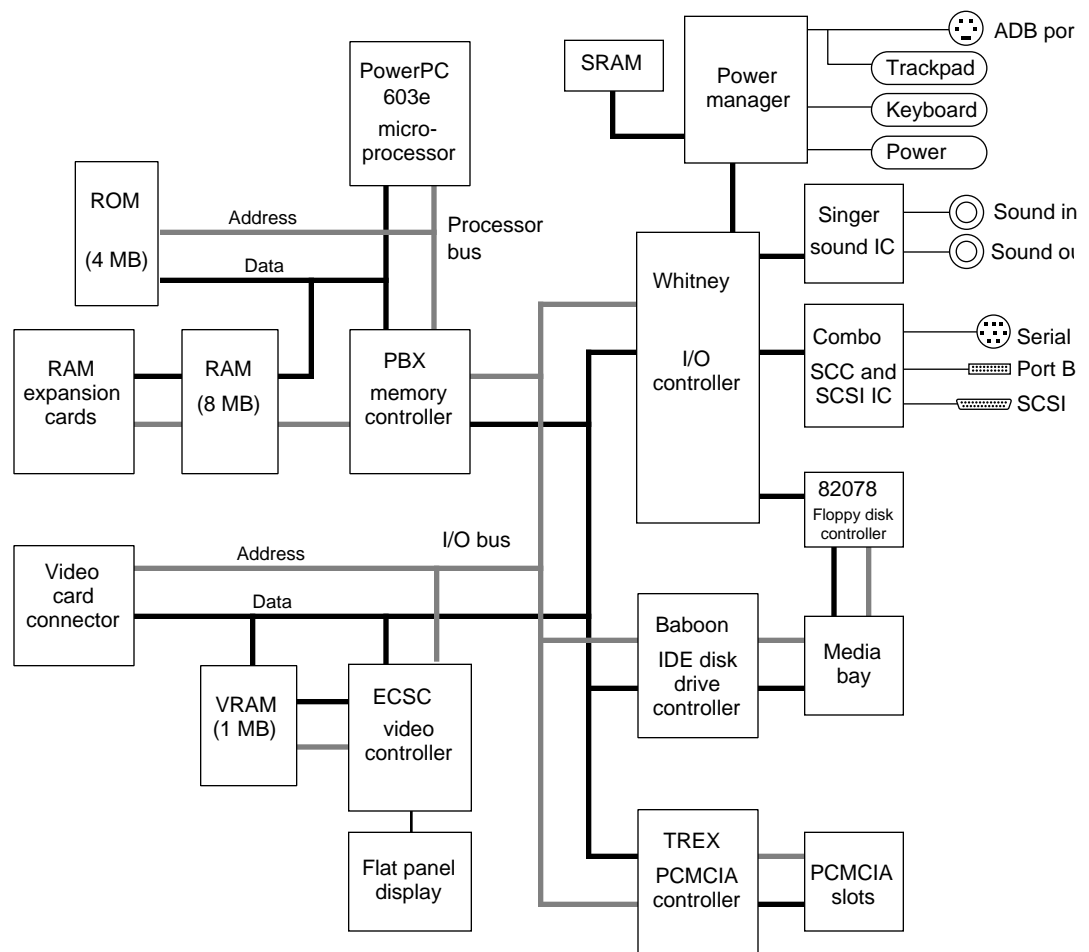
Figure 2-1 Block diagram

RAM

The PowerBook 1400 computer has 8 MB of dynamic RAM (DRAM) soldered on the main logic board. The computer comes with a factory-installed internal RAM expansion card that adds another 4 or 8 MB of RAM for a total of 12 or 16 MB of RAM. The RAM ICs are low-power, self-refreshing type with an access time of 70 ns.

In addition to the factory-installed RAM expansion card, one or two optional RAM expansion cards can be installed by way of an 80-pin connector on the logic board. With the full complement of RAM expansion cards, the computer supports up to 64 MB of RAM. See the section “RAM Expansion Cards” beginning on page 40 for details.

Memory control is provided by the PBX custom IC, which has a memory bank decoder in the form of an indexed register file. By writing the appropriate values into the register file at startup time, the system software makes the memory addresses contiguous from \$0000 0000 even if some banks are not populated. See “PBX Memory Controller IC” on page 10.

Architecture

ROM

The ROM in the PowerBook 1400 computer is implemented as a 1 M by 32-bit array consisting of two 1 M by 16-bit ROM ICs. The ROM devices support burst mode, so they do not degrade the performance of the PowerPC 603e microprocessor. The ROM ICs provide 4 MB of storage, which is located in the system memory map between addresses \$3000 0000 and \$3FFF FFFF. The ROM data path is 32 bits wide and addressable only as longwords. See Chapter 5, “Software Features,” for a description of the features of this new ROM.

PBX Memory Controller IC

The PBX IC is an Apple custom IC that provides RAM and ROM memory control and also acts as the bridge between the processor bus and the 68030-type I/O bus. The PBX IC also provides bus cycle decoding for the floppy disk controller.

Memory Control

The PBX IC controls the system RAM and ROM and provides address multiplexing and refresh signals for the DRAM devices. For information about the address multiplexing, see “Address Multiplexing” beginning on page 44.

The PBX IC has a memory bank decoder in the form of an indexed register file. Each nibble in the register file represents a 2 MB page in the memory address space (64 MB). The value in each nibble maps the corresponding page to one of the eight banks of physical RAM. By writing the appropriate values into the register file at startup time, the system software makes the memory addresses contiguous.

Bus Bridge

The PBX IC acts as a bridge between the processor bus and the I/O bus, converting signals on one bus to the equivalent signals on the other bus. The bridge functions are performed by two converters. One accepts requests from the processor bus and presents them to the I/O bus in a manner consistent with a 68030 microprocessor. The other converter accepts requests from the I/O bus and provides access to the RAM and ROM on the processor bus.

The bus bridge in the PBX IC runs asynchronously so that the processor bus and the I/O bus can operate at different rates. The processor bus operates at a clock rate of 33.33 MHz, and the I/O bus operates at 25.175 MHz.

Devices on the I/O Bus

The following components communicate by way of the I/O bus:

- the Whitney custom IC

Architecture

- the Combo I/O controller IC
- the Singer sound controller IC
- the Power Manager IC
- the display controller IC (ECSC)
- the video card connector
- the Baboon custom IC , which controls the expansion bay
- the 82078 IC , which controls a floppy disk drive in the expansion bay
- the TREX custom IC , which controls the PC card slots

The next sections describe these components.

Whitney Peripheral Support IC

The Whitney IC is a custom IC that provides the interface between the system bus and the I/O bus that supports peripheral device controllers. The Whitney IC incorporates the following circuitry:

- VIA1 like that in other Macintosh computers
- SWIM II floppy disk controller
- CPU ID register

The Whitney IC also performs the following functions:

- bus error timing for the I/O bus
- bus arbitration for the I/O bus
- interrupt prioritization
- VIA2 functions
- sound data buffering
- clock generation
- power control signals

The Whitney IC contains the interface circuitry for the following peripheral ICs:

- Combo, which is a combination of SCC and SCSI ICs
- Singer, the sound codec IC

The Whitney IC provides the device select signals for the following ICs:

- the flat panel display controller
- the external video controller

The Whitney IC also provides the power off and reset signals to the peripheral device ICs.

Architecture

Combo IC

The Combo custom IC combines the functions of the SCC IC (85C30 Serial Communications Controller) and the SCSI controller IC (53C80). The SCC portion of the Combo IC supports the serial I/O port. The SCSI controller portion of the Combo IC supports the external SCSI devices.

Singer IC

The Singer custom IC is a 16-bit digital sound codec. It conforms to the IT&T *ASCO 2300 Audio-Stereo Code Specification*. The Whitney IC maintains sound I/O buffers in main memory for sound samples being sent in or out through the Singer IC. For information about the operation of the Singer IC, see “Sound System” beginning on page 26.

Power Manager IC

The Power Manager IC is a 68HC05 microprocessor that operates with its own RAM and ROM. The Power Manager IC performs the following functions:

- controlling sleep, shutdown, and on/off modes
- controlling power to the other ICs
- controlling clock signals to the other ICs
- supporting the ADB
- scanning the keyboard
- controlling display brightness
- monitoring battery charge level
- controlling battery charging

Display Controller IC

An ECSC (enhanced color support chip) IC provides the data and control interface to the LCD panel. The ECSC IC contains a 256-entry CLUT, RAMDAC, display buffer controller, and flat panel control circuitry. For more information, see “Flat Panel Display Circuitry” on page 22.

Video Card Connector

The PowerBook 1400 computer accepts an optional video output card that drives an external video monitor. For more information, see “Expansion Card and Connector” beginning on page 52.

Baboon Custom IC

The Baboon custom IC provides the interface to the expansion bay. The IC performs four functions:

- controls the expansion bay
- controls the IDE interfaces, both internal and in the expansion bay
- buffers the floppy disk signals to the expansion bay
- decodes addresses for the PC card slots and the IDE controller

The Baboon IC controls the power to the expansion bay and the signals that allow the user to insert a device into the expansion bay while the computer is operating. Those signals are fully described in “Expansion Bay” beginning on page 30.

The Baboon IC controls the interface for both the internal IDE hard disk drive and a possible second IDE drive in the expansion bay. For information about the internal IDE drive see the section “Internal IDE Hard Disk Drive” beginning on page 16. For information about the IDE drive signals in the expansion bay, see “Signals on the Floppy Disk Connector” beginning on page 34, particularly Table 4-3 on page 35.

The Baboon IC also handles the signals to a floppy disk drive installed in the expansion bay. For more information, see “Signals on the Floppy Disk Connector,” particularly Table 4-3 on page 35.

The address decode portion of the Baboon IC provides address decoding for the IDE controller portion of the IC. It also provides the chip select decode for the TREX custom IC and address decoding for the two PC card slots.

Floppy Disk Controller IC

The floppy disk drive for the PowerBook 1400 computer is a 1.4 MB drive identical to those in previous PowerBook computers. The floppy disk controller is a standard 82078 IC.

The floppy disk drive for the PowerBook 1400 computer has a special signal, `DISK_IN_PLACE`, that indicates to the driver software whether a disk is present in the drive. For more information about the signal interface for devices in the expansion bay, see “Expansion Bay Connectors” beginning on page 34.

TREX Custom IC

The TREX custom IC provides the interface and control signals for the PC card slots. The main features of the TREX IC are

- the interrupt structure for the PC card slots
- transfers of single-byte and word data to and from the PC card slots
- power management for the PC card slots, including
 - sleep mode

Architecture

- control of power to individual sockets
- support of insertion and removal of PC cards while the computer is operating
- support for software control of card ejection
- support for time-division multiplexing (TDM), Apple Computer's technique for implementing PC cards for telecommunications

For more information about the operation of the PC card slots, see "PC Card Slot" beginning on page 57.

I/O Features

I/O Features

This chapter describes the input/output features of the PowerBook 1400 computer, including the built-in I/O devices and the ports for external I/O devices.

This chapter describes the following built-in devices and I/O ports:

- internal IDE hard disk drive
- built-in trackpad
- built-in keyboard
- built-in flat panel display
- serial port
- SCSI port
- Apple Desktop Bus (ADB) port
- IR module
- sound system

Internal IDE Hard Disk Drive

The PowerBook 1400 computer has an internal hard disk that uses the standard IDE (integrated drive electronics) interface. This interface, used for IDE drives on IBM AT-compatible computers, is also referred to as the ATA interface. The implementation of the ATA interface on the PowerBook 1400 computer is a subset of the ATA/IDE specification, ANSI proposal X3T10/0948D, Revision 2K (ATA-2).

The software that supports the internal hard disk is the same as that in previous Macintosh PowerBook models with internal IDE drives. For a complete description of the software, see “Software for ATA Devices” in *Macintosh Developer Note Number 14*.

Hard Disk Specifications

Figure 3-1 shows the maximum dimensions of the hard disk and the locations of the mounting holes. The minimum clearance between any conductive components on the drive and the bottom of the mounting envelope is 0.5 mm.

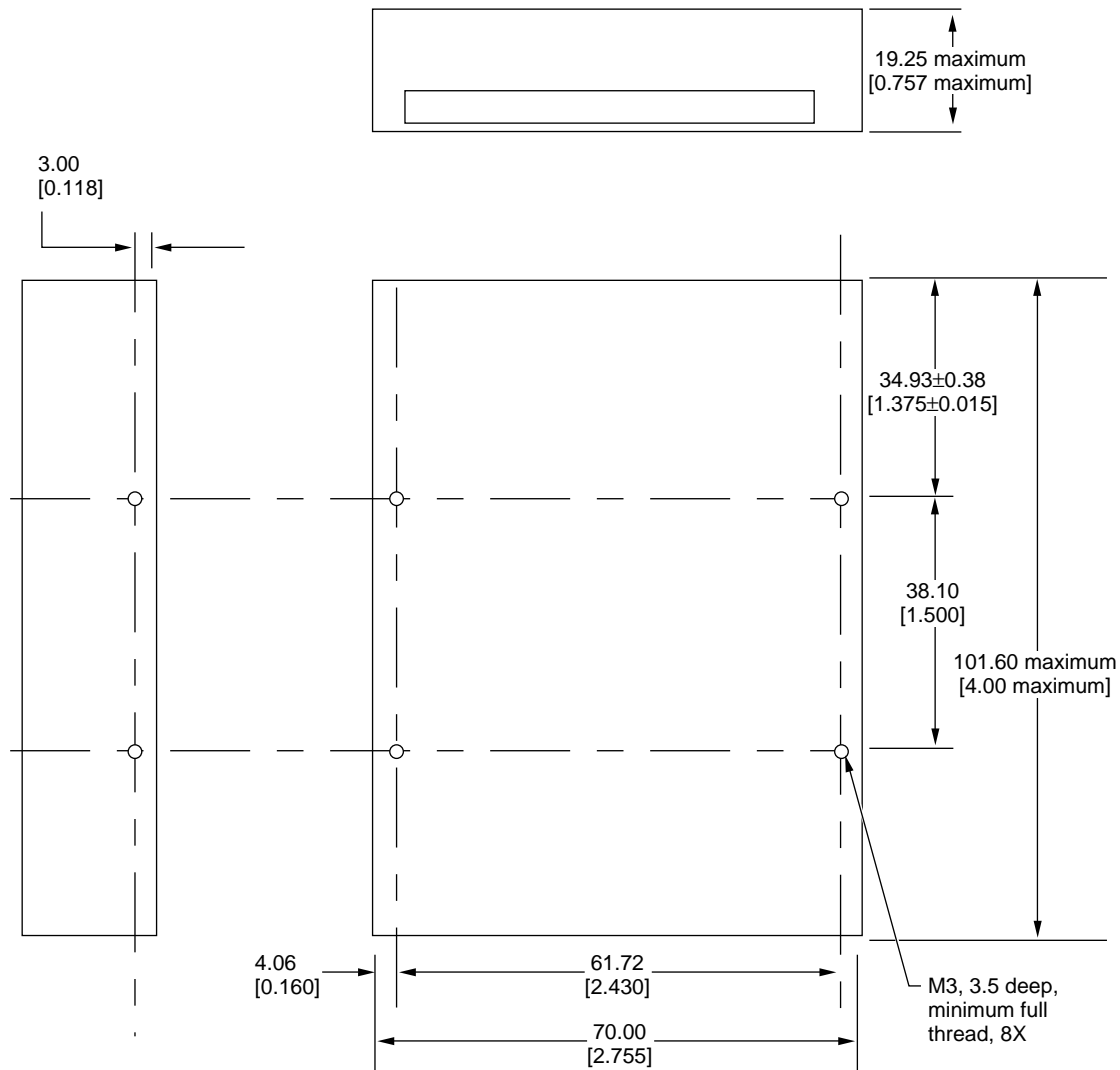
Figure 3-1 Maximum dimensions of the internal IDE hard disk

Note: Dimensions are in millimeters [inches]

Hard Disk Connector

The internal hard disk has a 48-pin connector that carries both the IDE signals and the power for the drive. The connector has the dimensions of a 50-pin connector, but with one row of pins removed, as shown in Figure 3-2. The remaining pins are in two groups: pins 1–44, which carry the signals and power, and pins 46–48, which are reserved. Notice that pin 20 has been removed, and that pin 1 is located nearest the gap, rather than at the end of the connector.

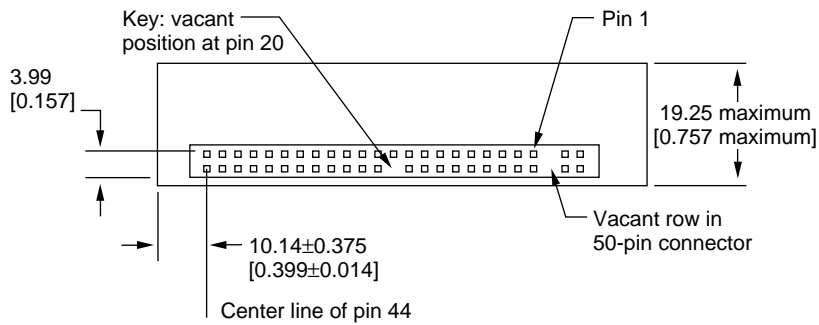
Figure 3-2 Connector for the internal IDE hard disk

Note: Dimensions are in millimeters [inches]

Signal Assignments

Table 3-1 shows the signal assignments on the 44-pin portion of the hard disk connector. A slash (/) at the beginning of a signal name indicates an active-low signal.

Table 3-1 Signal assignments on the IDE hard disk connector

Pin number	Signal name	Pin number	Signal name
1	/RESET	2	GROUND
3	DD7	4	DD8
5	DD6	6	DD9
7	DD5	8	DD10
9	DD4	10	DD11
11	DD3	12	DD12
13	DD2	14	DD13
15	DD1	16	DD14
17	DD0	18	DD15
19	GROUND	20	KEY
21	DMARQ	22	GROUND
23	/DIOW	24	GROUND
25	/DIOR	26	GROUND
27	IORDY	28	CSEL
29	/DMACK	30	GROUND

continued

Table 3-1 Signal assignments on the IDE hard disk connector (continued)

Pin number	Signal name	Pin number	Signal name
31	INTRQ	32	/IOCS16
33	DA1	34	/PDIAG
35	DA0	36	DA2
37	/CS0	38	/CS1
39	/DASP	40	GROUND
41	+5V LOGIC	42	+5V MOTOR
43	GROUND	44	Reserved

IDE Signal Descriptions

Table 3-2 describes the signals on the IDE hard disk connector.

Table 3-2 Signals on the IDE hard disk connector

Signal name	Signal description
/CS0	IDE register select signal. It is asserted low to select the main task file registers. The task file registers indicate the command, the sector address, and the sector count.
/CS1	IDE register select signal. It is asserted low to select the additional control and status registers on the IDE drive.
CSEL	Cable select; if CSEL is asserted, the device address is 1; if negated, the device address is 0.
DA(0–2)	IDE device address; used by the computer to select one of the registers in the IDE drive. For more information, see the descriptions of the /CS0 and /CS1 signals.
/DASP	Device active or slave present.
DD(0–15)	IDE data bus; buffered from IOD(16–31) of the computer's I/O bus. DD(0–15) are used to transfer 16-bit data to and from the drive buffer. DD(8–15) are used to transfer data to and from the internal registers of the drive, with DD(0–7) driven high when writing.
/DIOR	IDE I/O data read strobe.
/DIOW	IDE I/O data write strobe.
/DMACK	Used by the host to initiate a DMA transfer in response to DMARQ.
DMARQ	Asserted by the device when it is ready to transfer data to or from the host.

continued

Table 3-2 Signals on the IDE hard disk connector (continued)

Signal name	Signal description
INTRQ	IDE interrupt request. This active-high signal is used to inform the computer that a data transfer is requested or that a command has terminated.
/IOCS16	IDE I/O channel select; asserted low for an access to the data port. The computer uses this signal to indicate a 16-bit data transfer.
IORDY	IDE I/O ready; when driven low by the drive, signals the CPU to insert wait states into the I/O read or write cycles.
KEY	This pin is the key for the connector.
/PDIAG	Asserted by device 1 to indicate to device 0 that it has completed the power-on diagnostics.
/RESET	Hardware reset to the drive; an active-low signal.

The IDE data bus is connected to the I/O bus through bidirectional bus buffers. To match the big-endian format of the 68030-compatible I/O bus, the bytes are swapped. The lowest byte of the IDE data bus, DD(0–7), is connected to the high byte of the upper word of the I/O bus, IOD(24–31). The highest byte of the IDE data bus, DD(8–15), is connected to the low byte of the upper word of the I/O bus, IOD(16–23).

Trackpad

The pointing device in the PowerBook 1400 computer is a trackpad, an integrated flat pad that replaces the trackball used in previous PowerBook computers. The trackpad provides precise cursor positioning in response to motions of the user's fingertip over the surface of the pad. A single button below the trackpad is used to make selections.

The trackpad is a solid-state device that emulates a mouse by sensing the motions of the user's finger over its surface and translating those motions into ADB commands. The trackpad is lighter and more durable than the trackball used in earlier PowerBook computers, and it consumes less power.

The trackpad includes tap and double-tap features. As described in the user's manual, the trackpad responds to one or two taps on the pad itself as one or two clicks of the button. The user can tap and drag on the trackpad in much the same manner as clicking and dragging with the mouse.

Keyboard

The keyboard provides 76 (United States) or 77 (ISO) keys, including 12 function keys. Figure 3-3 shows the version of the keyboard used on machines sold in the United States.

I/O Features

Figure 3-4 shows the version of the keyboard used on machines sold in countries that require the ISO standard.

Figure 3-3 Keyboard, U.S. layout



Figure 3-4 Keyboard, ISO layout



The Caps Lock key does not latch down. To indicate whether the caps lock is engaged, a software extension displays an icon in the menu bar.

The user can remove the keyboard to obtain access to the internal components and expansion connectors inside the computer. The keyboard is held in place by the perforated speaker grille. After sliding the grille to the left and lifting it out, the user can lift out the keyboard, which remains connected by a flexible ribbon cable.

Types of Displays

Flat panel displays come in two types: active-matrix and passive matrix.

Active-matrix displays, also called thin-film transistor (TFT) displays, have a driving transistor for each individual pixel. The driving transistors give active-matrix displays high contrast and fast response time.

Passive matrix refers to a display technology that does not have individual transistors. That technology is also called FSTN, for film supertwist nematic, sometimes shortened to just supertwist. DualScan is Apple Computer's improved type of FSTN color display.

Flat Panel Display

The PowerBook 1400 computer has a built-in flat panel display. Two display options are available, as shown in Table 3-3. Both displays are backlit by a cold cathode fluorescent lamp (CCFL). Both displays can show up to thousands of colors (16 bits per pixel).

Table 3-3 Characteristics of the displays

Display type	Size (pixels)	Dot pitch (mm)	Number of colors or grays
11.3-inch DualScan color (FSTN)	800 by 600	0.27	Thousands
11.3-inch active-matrix color (TFT)	800 by 600	0.27	Thousands

Flat Panel Display Circuitry

The flat panel display circuitry in the PowerBook 1400 computer emulates a NuBus[™] video card installed in slot \$0. There is no declaration ROM as such; its functions have been incorporated into the system ROM. The display circuitry includes the new ECSC controller IC and a display buffer consisting of 1 MB of VRAM. The LCD display is compatible with software that uses QuickDraw and the Palette Manager. The display supports color-table animation.

Number of Colors

The display controller IC contains a 256-entry CLUT. Although the CLUT supports a palette of thousands of colors, many of the possible colors do not look acceptable on the display. Due to the nature of color LCD technology, some colors are dithered or exhibit noticeable flicker. Apple has developed new gamma tables for these displays that minimize flicker and optimize available colors. With these gamma tables, the effective range of the CLUT for the active-matrix color display is about 260,000 colors; for the DualScan color display, the effective range is about 4000 colors.

Serial Port

The PowerBook 1400 computer has a standard Macintosh serial port for synchronous, asynchronous, or AppleTalk serial communication. The 8-pin mini-DIN connector on the back panel is the same as those on other Macintosh computers. Figure 3-5 shows the connector, and Table 3-4 shows the signal assignments for the serial port.

Figure 3-5 Serial port connector

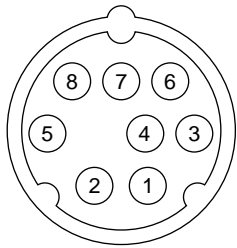

Table 3-4 Serial port signals

Pin number	Signal name	Signal description
1	HSKo	Handshake output
2	HSKi	Handshake input
3	TxD-	Transmit data -
4	SG	Signal ground
5	RxD-	Receive data -
6	TxD+	Transmit data +
7	GPi	General-purpose input
8	RxD+	Receive data +

SCSI Port

The SCSI port on the PowerBook 1400 computer supports the SCSI interface as defined by the American National Standards Institute (ANSI) X3T9.2 committee.

The external HDI-30 connector is identical to those used in other PowerBook models. The SCSI portion of the Combo IC connects directly to the external SCSI connector and

I/O Features

can sink up to 48 mA through each of the pins connected to the SCSI bus. The data and control signals on the SCSI bus are active-low signals that are driven by open drain outputs.

Table 3-5 shows the signal assignments for the external SCSI connector. Note that pin 1 of the external SCSI connector is the /SCSI.DISK.MODE signal.

Table 3-5 SCSI connector signals

Pin number	Signal name	Pin number	Signal name
1	/SCSI.DISK.MODE	16	/DB6
2	/DB0	17	GND
3	GND	18	/DB7
4	/DB1	19	/DBP
5	TERMPWR (not used; reserved for future use)	20	GND
6	/DB2	21	/REQ
7	/DB3	22	GND
8	GND	23	/BSY
9	/ACK	24	GND
10	GND	25	/ATN
11	/DB4	26	/C/D
12	GND	27	/RST
13	GND	28	/MSG
14	/DB5	29	/SEL
15	GND	30	/I/O

ADB Port

The Apple Desktop Bus (ADB) port on the PowerBook 1400 computer is functionally the same as on other Macintosh computers.

The ADB connector is a 4-pin mini-DIN connector. Figure 3-6 shows the arrangement of the pins on the ADB connector.

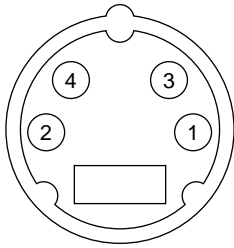
Figure 3-6 ADB connector

The ADB is a single-master, multiple-slave serial communications bus that uses an asynchronous protocol and connects keyboards, graphics tablets, mouse devices, and other devices to the computer. The custom ADB microcontroller drives the bus and reads status from the selected external device. A 4-pin mini-DIN connector connects the ADB controller to the outside world. Table 3-6 lists the ADB connector pin assignments. For more information about the ADB, see *Guide to the Macintosh Family Hardware*, second edition.

Table 3-6 ADB connector pin assignments

Pin number	Name	Description
1	ADB	Bidirectional data bus used for input and output; an open collector signal pulled up to +5 volts through a 470-ohm resistor on the main logic board.
2	PSW	Power on signal; generates reset and interrupt key combinations.
3	+5V	+5 volts from the computer.
4	GND	Ground from the computer.

IMPORTANT

The total current available for all devices connected to the +5V pins on the ADB is 100 mA. ▲

Infrared Link

The computer has an infrared (IR) link connected internally to serial port B. The IR link can communicate with other PowerBook computers that have IR links. When the computer is placed within a few feet of another machine with an IR link, it can send and receive serial data at up to 230 KB per second.

I/O Features

For LocalTalk operation, the IR module takes serial bits from the SCC and transmits them using a modified form of pulse encoding called PPM-4. This method of encoding uses four cycles of a 3.92 MHz carrier for each pulse, which increases the system's immunity to interference from fluorescent lights.

Sound System

The 16-bit stereo audio circuitry provides high-quality sound input and output through the built-in microphone and speaker. The user can also connect external input and output devices by way of the sound input and output jacks.

The sound system is based on the Singer codec IC along with input and output amplifiers and signal conditioners. In the PowerBook 1400 computer, the Singer codec supports two channels of digital sound with sample sizes up to 16 bits and sample rates of 11.025 kHz, 22.05 kHz, and 44.1 kHz.

The frequency response of the sound circuits, not including the microphone and speaker, is within plus or minus 2 dB from 20 Hz to 20 kHz. Total harmonic distortion and noise is less than 0.05 percent with a 1V rms sine wave input. The signal-to-noise ratio (SNR) is 85 dB, with no audible discrete tones.

Note

All sound level specifications in this section are rms values. ♦

Sound Inputs

The sound system accepts inputs from several sources:

- built-in microphone
- external sound input jack
- sound from the expansion bay
- 1-bit sound from the PC card slot

The sound signal from the built-in microphone goes through a dedicated preamplifier that raises its nominal 30 mV level to the 1 V level of the codec circuits in the Singer IC.

Stereo sound signals from the external sound input jack go through an analog multiplexer that selects either the external signals or the sound signals from the expansion bay. The multiplexer also lowers the levels of the maximum 2 V signal at the input jack to match the 1 V level of the codec circuits in the Singer IC.

The sound input jack has the following electrical characteristics:

- input impedance: 6.8k Ω
- maximum level: 2.0 V rms

I/O Features

Note

The sound input jack accepts the maximum sound output of an audio CD without clipping. When working with sound sources that have significantly lower levels, you may wish to increase the sound output level. You can do that using the Sound Manager as described in *Inside Macintosh: Sound*. ♦

Stereo sound signals from the expansion bay go through an analog multiplexer that selects either those signals or the line signals from the external input jack. The multiplexer also raises the nominal 0.5 V level of the expansion bay sound to the 1 V input level of the codec circuits.

The sound input from the expansion bay has the following electrical characteristics:

- input impedance: 3.2k Ω
- maximum level: 0.5 V rms

Each PC card has one sound output pin (SPKR_OUT), and the computer accepts either one or two cards. The 1-bit digital signals from the sound output pins are exclusive-ORed together and routed to the built-in speaker and the external sound output jack.

Sound Outputs

The sound system sends computer-generated sounds or sounds from an expansion bay device or PC card to a built-in speaker and to an external sound output jack. The sound output jack is located on the back of the computer.

The sound output jack provides enough current to drive a pair of low-impedance headphones. The sound output jack has the following electrical characteristics:

- output impedance: 33 Ω
- minimum recommended load impedance: 32 Ω
- maximum level: 1 V rms
- maximum current: 32 mA peak

The computer turns off the sound signals to the internal speaker when an external device is connected to the sound output jack and during power cycling.

Expansion Modules

Expansion Modules

This chapter describes the following expansion features of the PowerBook 1400 computer:

- expansion bay
- RAM expansion cards
- expansion card connector
- PC card slot

Expansion Bay

The expansion bay is an opening in the PowerBook 1400 computer that accepts a plug-in disk drive such as a floppy disk or CD-ROM drive.

Expansion Bay Module for Floppy Disk

Figure 4-1 shows a side view of a floppy-disk module designed to fit into the expansion bay. Figure 4-2 shows a top view of such a module and Figure 4-3 shows a bottom view.

Figure 4-1 Side view of a floppy disk module

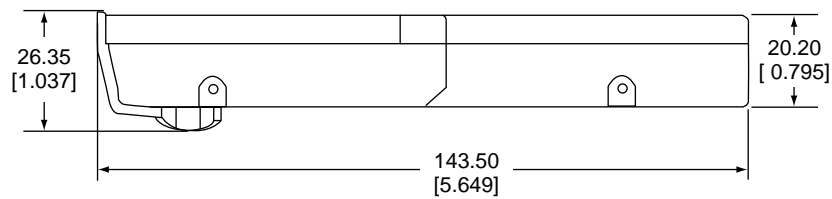

Note: Dimensions are in millimeters [inches]

Figure 4-2 Top view of a floppy disk module

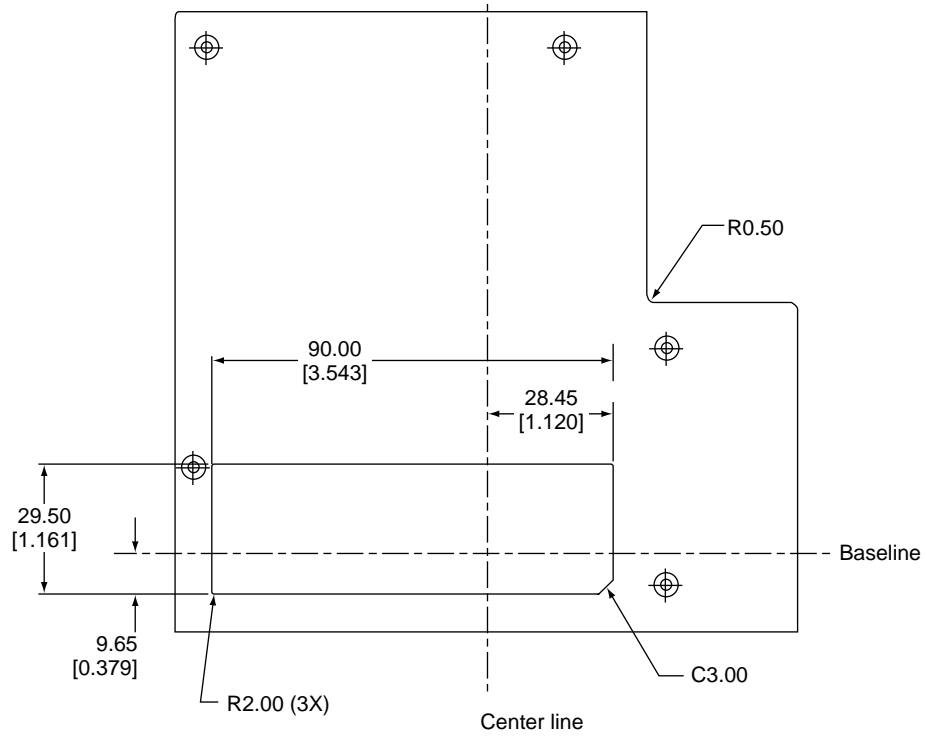

Note: Dimensions are in millimeters [inches].

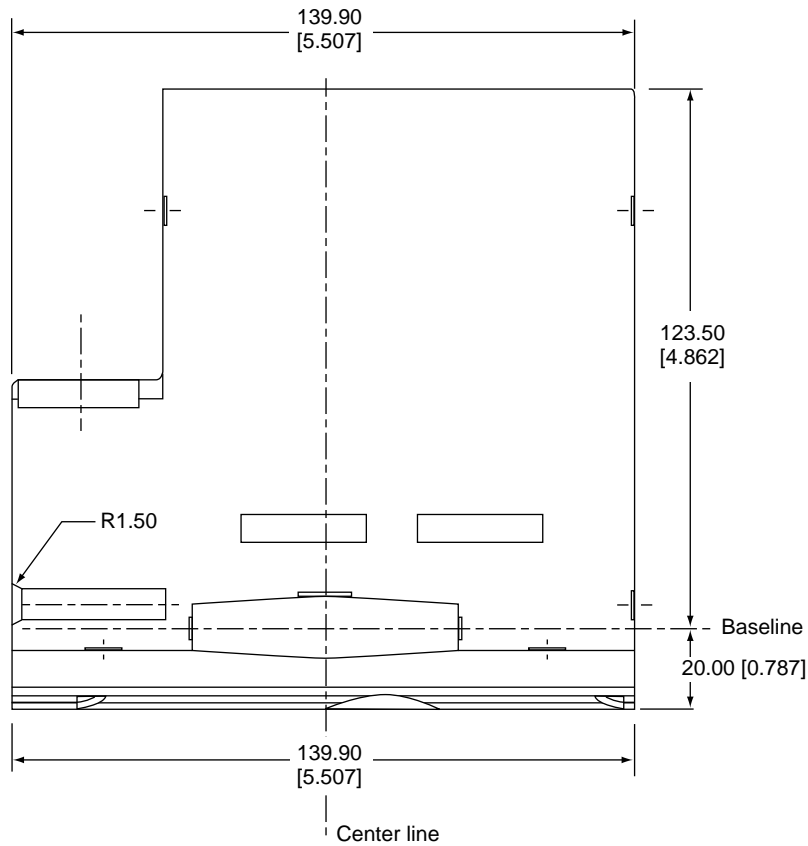
Figure 4-3 Bottom view of a floppy disk module

Note: Dimensions are in millimeters [inches].

Expansion Bay Module for CD-ROM

Figure 4-4 shows a top view of a CD-ROM module designed to fit into the expansion bay. Figure 4-5 shows a bottom view of such a module.

Note

An expansion bay module for an IDE hard disk drive would be the same dimensions and use the same connector as a module for a CD-ROM drive. ♦

Figure 4-4 Top view of a CD-ROM module

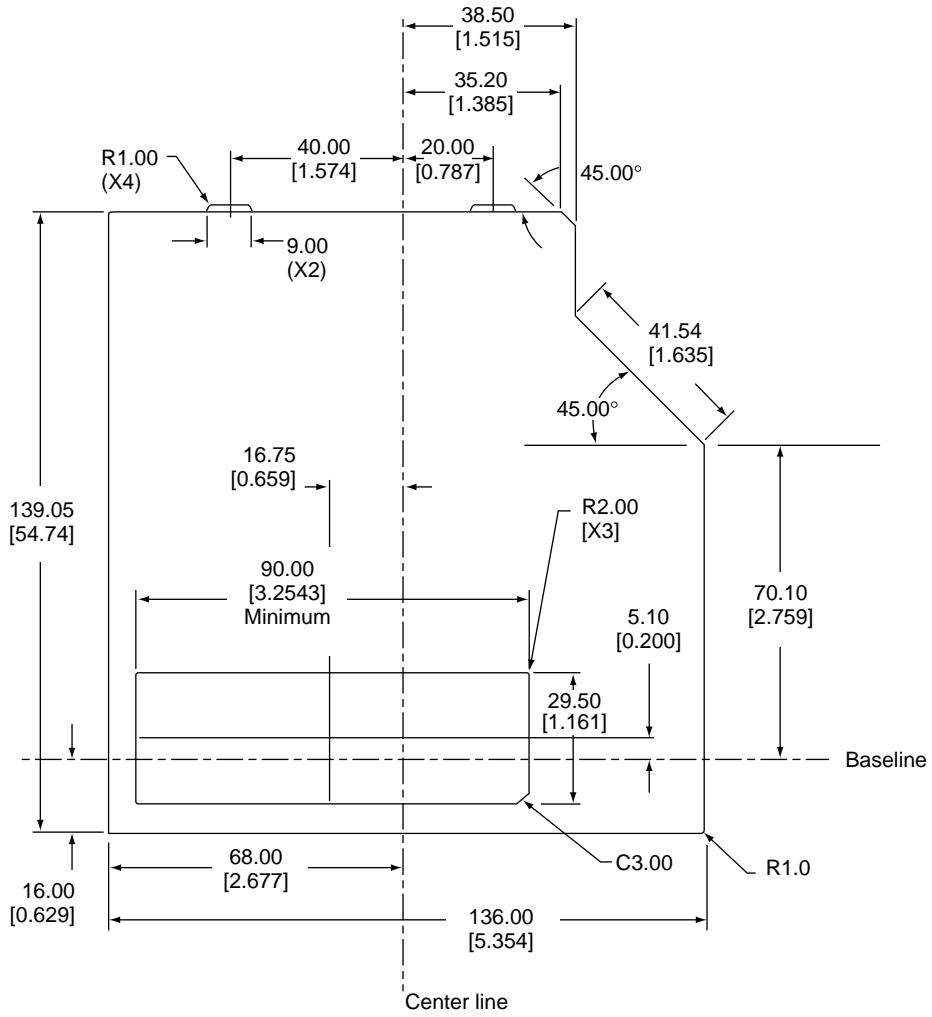

Note: Dimensions are in millimeters [inches].

Figure 4-5 Bottom view of a CD-ROM module

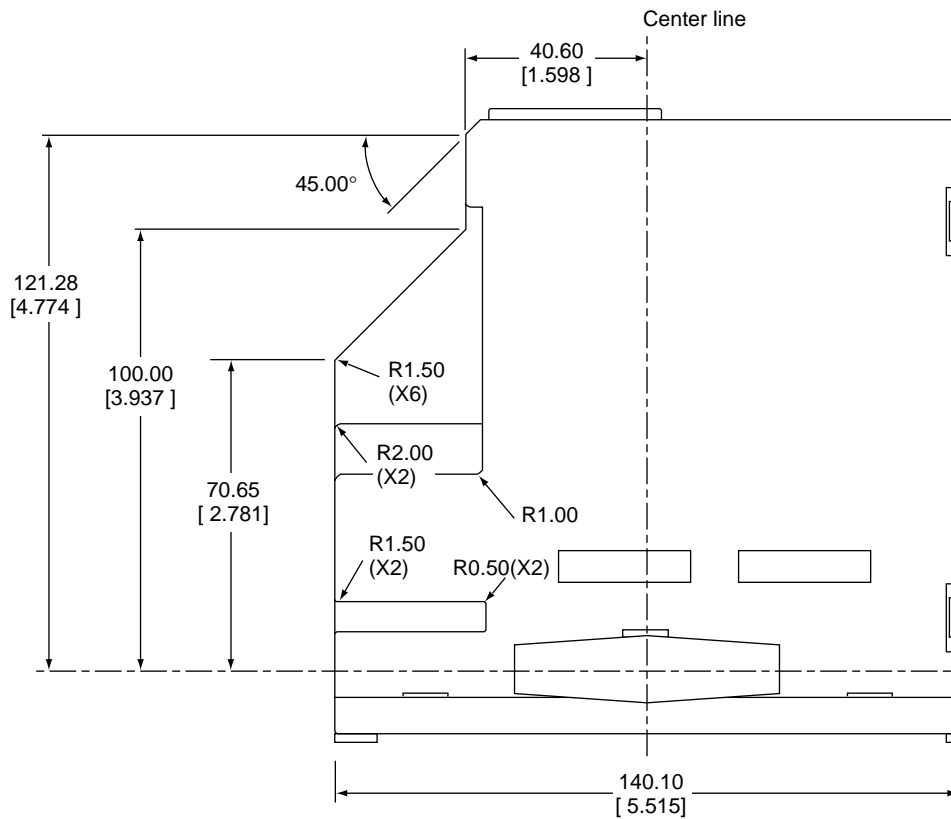

Note: Dimensions are in millimeters [inches].

Expansion Bay Connectors

The expansion bay has separate connectors for a floppy disk module and a CD-ROM or hard disk module. Table 4-1 shows the part numbers for connectors manufactured by KEL Connectors, Incorporated.

Table 4-1 Connectors for expansion bay modules

Type of module	Connector in computer	Connector on module
Floppy-disk	89BF-020R	89BM-020R
CD-ROM or hard disk	8901-040-177L	8913-040-178MS-A

Signals on the Floppy Disk Connector

Table 4-2 shows the signal assignments on the floppy disk connector. Signal names that begin with a slash (/) are active low.

Expansion Modules

Table 4-2 Signal assignments on the floppy disk connector

Pin	Signal name	Pin	Signal name
1	MB_+5V	2	WRDATA
3	MB_+5V	4	DEV_ID(2)
5	/FL_ENABLE	6	GND
7	GND	8	HDSEL
9	DEV_ID(1)	10	GND
11	/DEV_IN	12	GND
13	DEV_ID(0)	14	/WRREQ
15	GND	16	PHASE(3)
17	FD_RDATA	18	PHASE(2)
19	PHASE(0)	20	PHASE(1)

Table 4-3 describes the signals on the floppy disk connector.

Table 4-3 Signals on the floppy disk connector

Signal name	Signal description
DEV_ID(2–0)	These three signal lines identify the type of expansion-bay device. A value of 000b identifies a floppy-disk drive; 011b identifies all other IDE devices.
/DEV_IN	This signal is low whenever a device is installed in the expansion bay; it is used by the Baboon IC to determine when a device has been inserted or removed.
FD_RDATA	Read data from the floppy disk drive.
/FL_ENABLE	Floppy disk drive enable.
GND	Ground.
HDSEL	Head select.
MB_+5V	5 V power; maximum total current is 1.0 A.
PHASE(3–0)	PHASE(2–0) are state-control lines to the drive; PHASE(3) is the strobe signal for writing to the drive's control registers.
WRDATA	Write data to the floppy disk drive.
/WRREQ	Write data request signal.

Expansion Modules

Signals on the CD-ROM Connector

Table 4-4 shows the signal assignments on the CD-ROM connector. Signal names that begin with a slash (/) are active low.

Table 4-4 Signal assignments on the CD-ROM connector

Pin	Signal name	Pin	Signal name
1	/MB_IDE_RST	2	GND
3	IDE_D(7)	4	IDE_D(8)
5	IDE_D(6)	6	IDE_D(9)
7	IDE_D(5)	8	IDE_D(10)
9	IDE_D(4)	10	IDE_D(11)
11	IDE_D(3)	12	IDE_D(12)
13	IDE_D(2)	14	IDE_D(13)
15	IDE_D(1)	16	IDE_D(14)
17	IDE_D(0)	18	IDE_D(15)
19	DEV_ID(2)	20	/DEV_IN
21	/DIOV	22	/DIOR
23	IOCHRDY	24	GND
25	GND	26	IDE_INTRQ
27	DEV_ID(1)	28	IDE_ADDR(1)
29	DEV_ID(0)	30	IDE_ADDR(0)
31	IDE_ADDR(2)	32	/CS1FX
33	/CS3FX	34	n.c.
35	MB_+5V	36	MB_+5V
37	MB_SND_L	38	MB_SND_COM
39	MB_SND_COM	40	MB_SND_R

An IDE hard disk drive in an expansion module uses the CD-ROM connector. Table 4-5 shows the signal assignments for a hard disk drive. The table shows the signal pins both

Expansion Modules

at the 40-pin CD-ROM connector on the expansion module and at the 44-pin connector on the hard disk drive. Signal names that begin with a slash (/) are active low.

Table 4-5 Signal assignments for a hard disk drive

Pin numbers			Pin numbers		
CD-ROM connector	Hard disk connector	Signal name	CD-ROM connector	Hard disk connector	Signal name
1	1	/INT_IDE_RST	2	2	GND
3	3	IDE_D(7)	4	4	IDE_D(8)
5	5	IDE_D(6)	6	6	IDE_D(9)
7	7	IDE_D(5)	8	8	IDE_D(10)
9	9	IDE_D(4)	10	10	IDE_D(11)
11	11	IDE_D(3)	12	12	IDE_D(12)
13	13	IDE_D(2)	14	14	IDE_D(13)
15	15	IDE_D(1)	16	16	IDE_D(14)
17	17	IDE_D(0)	18	18	IDE_D(15)
19	—	(Unused)	20	—	(Unused)
21	23	/DIOW	22	25	/DIOR
23	27	IOCHRDY	24	19	GND
25	22	GND	26	31	HD_INT
27	—	(Unused)	28	33	IDE_ADDR(1)
29	—	(Unused)	30	35	IDE_ADDR(0)
31	36	IDE_ADDR(2)	32	37	INT/CS1FX
33	38	INT/CS3FX	34	—	(Unused)
35	41	MB_+5V	36	42	MB_+5V
37, 39	—	(Unused)	38, 40	—	(Unused)
—	20, 21, 28, 29, 32, 39	(Unused)	—	24, 26, 30, 40	GND
—	43	GND	—	44	(470Ω to +5V)

For specifications of signal levels and protocol for attachment to the expansion bay, developers should refer to ANSI specification *X3T13-1153D AT Attachment-4 with Packet Interface Extension (ATA/ATAPI-4), Revision 2*.

Table 4-6 describes the signals on the CD-ROM connector.

Table 4-6 Signals on the CD-ROM connector

Signal name	Signal description
/CS1FX	IDE register select signal. It is asserted low to select the main task file registers. The task file registers indicate the command, the sector address, and the sector count.
/CS3FX	IDE register select signal. It is asserted low to select the additional control and status registers on the IDE drive.
DEV_ID(2:0)	These three signal lines identify the type of expansion-bay device. A value of 000b identifies a floppy-disk drive; 011b identifies all other IDE devices.
/DEV_IN	This signal is low whenever a device is installed in the expansion bay; it is used by the Baboon IC to determine when a device has been inserted or removed.
/DIOR	IDE I/O data read strobe.
/DIOW	IDE I/O data write strobe.
GND	Ground.
IDE_ADDR(0–2)	IDE device address; used by the computer to select one of the registers in the IDE drive. For more information, see the descriptions of the /CS1FX and /CS3FX signals.
IDE_D(0–15)	IDE data bus, buffered from IOD(16–31) of the controller IC. IDE_D(0–15) are used to transfer 16-bit data to and from the drive buffer. IDE_D(0–7) are used to transfer data to and from the drive's internal registers, with IDE_D(8–15) driven high when writing.
IDE_INTRQ	IDE interrupt request. This active-high signal is used to inform the computer that a data transfer is requested or that a command has terminated.
IOCHRDY	IDE I/O channel ready; when driven low by the IDE drive, signals the CPU to insert wait states into the I/O read or write cycles.
MB_+5V	5 V power; maximum total current is 1.0 A.
/MB_IDE_RST	Hardware reset to the IDE drive.
MB_SND_COM	Common (ground) line for expansion bay sound signals.
MB_SND_L	Left channel sound signal from the expansion bay device.
MB_SND_R	Right channel sound signal from the expansion bay device.

Unused Signals

Several signals defined in the standard interface for the IDE drive are not used by the expansion bay. Those signals are listed in Table 4-7 along with any action required for the device to operate in the expansion bay.

Table 4-7 Unused IDE signals

Signal name	Comment
DMARQ	No action required.
CSEL	This signal must be tied to ground to configure the device as the master in the default mode.
DMACK	This signal must be pulled high (to the IDE device's +5V).
IOCS16	No action required.
PDIAG	No action required; the device is never operated in master-slave mode.
DAS	No action required.

User Installation of an Expansion Bay Module

The user can insert a module into the expansion bay while the computer is in sleep mode. This section describes the sequence of control events in the computer and gives guidelines for designing an expansion bay module so that such insertion does not cause damage to the module or the computer.

▲ WARNING

The user must not insert or remove a module from the expansion bay while the computer is operating. It is safe to do so only while the computer is in sleep mode or is off. Insertion or removal of a module from the expansion bay while the computer is operating may cause corruption of the internal hard disk. ▲

Sequence of Control Signals

Specific signals to the Baboon IC and the Power Manager IC allow the computer to detect the insertion of a module into the expansion bay and take appropriate action. For example, when a module with an IDE device is inserted, the computer performs the following sequence of events:

1. When a module is inserted, the /DEV_IN signal goes low, causing the Baboon IC to generate an interrupt.
2. The Power Manager IC reads the three DEV_ID signals, which identify the device as an IDE device.
3. System software responds to the interrupt and sets a signal that turns on the power to the expansion bay.

Expansion Modules

4. When the expansion bay power goes high, the Baboon IC generates another interrupt.
5. System software responds to the power-on interrupt and asserts a signal to enable the IDE bus in the expansion bay.
6. The software then releases the `/MB_IDE_RST` signal from the Power Manager IC, allowing the IDE device to begin operating.

Essentially the reverse sequence occurs when a module is removed from the expansion bay:

1. When the module is removed, the `/DEV_IN` signal goes high causing the Baboon IC to generate an interrupt and set `/MB_OE` high, disabling the IDE bus.
2. System software responds to the interrupt by reading the device ID settings in the Power Manager IC, setting the `/MB_PWR_EN` signal high to turn off the power to the expansion bay, and asserting the `/MB_IDE_RST` signal to disable the IDE drive.

Guidelines for Developers

Each expansion bay module must be designed to prevent damage to itself and to the computer when the user inserts or removes the module with the computer running.

The expansion bay connector is designed so that when the module is inserted, the ground and power pins make contact before the signal lines.

Even though you can design an expansion bay module that minimizes the possibility of damage when it is inserted hot—that is, while the computer is running—your instructions to the user should include warnings against doing so.

RAM Expansion Cards

The PowerBook 1400 computer can accommodate as many as three RAM expansion cards: one factory-installed card and two user-installed cards. All three cards are connected to the same signal lines and have the same electrical characteristics. The user-installed cards are slightly larger than the factory-installed card and have two connectors. When both user-installed cards are installed, they stack one above the other. The first user-installed card plugs into the logic board; the second card plugs into the first one.

IMPORTANT

The RAM expansion cards for the PowerBook 1400 computer have a new design. RAM expansion cards for earlier PowerBook models will not work in this computer. ▲

The factory-installed RAM expansion card contains 4 or 8 MB of self-refreshing dynamic RAM. The user-installed RAM expansion cards can contain from 8 MB to 48 MB of self-refreshing dynamic RAM.

▲ WARNING

Installation of a RAM expansion card must be performed by an experienced technician. Installation requires care to avoid damage to the pins on the RAM expansion connector. ▲

Electrical Design Guidelines for the RAM Expansion Cards

This section provides the electrical information you need to design RAM expansion cards for the PowerBook 1400 computer. The mechanical specifications are given in “Mechanical Design of the RAM Expansion Cards” beginning on page 49.

Connector Pin Assignments

The computer has two RAM expansion connectors: one for the factory-installed card and one for the user-installed cards. Both connectors have the same number of pins. Table 4-8 lists the names of the signals on both RAM expansion connectors. Many of the signals are the same on both connectors, but some of the signals on the connector for user-installable card are buffered, where the corresponding signals on the connector for the factory-installed card are not. See “Signal Descriptions” beginning on page 43 for information about the signals on the two connectors.

Entries in Table 4-8 are arranged the same way as the pins on the connector: pin 1 across from pin 2, and so on. Signal names that begin with a slash (/) are active low.

Table 4-8 Signals on the RAM expansion connectors

Pin	Signal name on factory RAM connector	Signal name on user RAM connector	Pin	Signal name on factory RAM connector	Signal name on user RAM connector
1	+5V_MAIN	PCMCIA_VPP	2	+5V_MAIN	+5V_MAIN
3	+5V_MAIN	+5V_MAIN	4	PD(0)	PD(0)
5	/CAS(0)	/RCAS(0)	6	PD(1)	PD(1)
7	MA(0)	RMA(0)	8	PD(2)	PD(2)
9	GND	GND	10	PD(3)	PD(3)
11	GND	GND	12	PD(4)	PD(4)
13	MA(1)	RMA(1)	14	PD(5)	PD(5)
15	MA(2)	RMA(2)	16	PD(6)	PD(6)
17	MA(3)	RMA(3)	18	PD(7)	PD(7)
19	MA(4)	RMA(4)	20	GND	GND
21	MA(5)	RMA(5)	22	GND	GND
23	/CAS(1)	/RCAS(1)	24	PD(8)	PD(8)

continued

Table 4-8 Signals on the RAM expansion connectors (continued)

Pin	Signal name on factory RAM connector	Signal name on user RAM connector	Pin	Signal name on factory RAM connector	Signal name on user RAM connector
25	MA(6)	RMA(6)	26	PD(9)	PD(9)
27	/RAS(1)	/RRAS(2)	28	PD(10)	PD(10)
29	GND	GND	30	PD(11)	PD(11)
31	GND	GND	32	PD(12)	PD(12)
33	n.c.	/RRAS(3)	34	PD(13)	PD(13)
35	n.c.	/RRAS(4)	36	PD(14)	PD(14)
37	/RAMWE	/RRAMWE	38	PD(15)	PD(15)
39	+5V_MAIN	+5V_MAIN	40	+5V_MAIN	+5V_MAIN
41	+5V_MAIN	+5V_MAIN	42	+5V_MAIN	+5V_MAIN
43	/RAMOE	/RAMOE	44	PD(16)	PD(16)
45	n.c.	/RRAS(5)	46	PD(17)	PD(17)
47	n.c.	/RRAS(6)	48	PD(18)	PD(18)
49	GND	GND	50	PD(19)	PD(19)
51	GND	GND	52	PD(20)	PD(20)
53	/RAS(1)	/RRAS(7)	54	PD(21)	PD(21)
55	/CAS(2)	/RCAS(2)	56	PD(22)	PD(22)
57	MA(7)	RMA(7)	58	PD(23)	PD(23)
59	+5V_MAIN	+5V_MAIN	60	GND	GND
61	+5V_MAIN	+5V_MAIN	62	GND	GND
63	MA(8)	RMA(8)	64	PD(24)	PD(24)
65	MA(9)	RMA(9)	66	PD(25)	PD(25)
67	MA(10)	RMA(10)	68	PD(26)	PD(26)
69	GND	GND	70	PD(27)	PD(27)
71	GND	GND	72	PD(28)	PD(28)
73	MA(11)	RMA(11)	74	PD(29)	PD(29)
75	/CAS(3)	/RCAS(3)	76	PD(30)	PD(30)
77	+5V_MAIN	+5V_MAIN	78	PD(31)	PD(31)
79	+5V_MAIN	+3V_MAIN	80	+5V_MAIN	+3V_MAIN

Expansion Modules

Signal Descriptions

Table 4-9 describes the signals on the RAM expansion connectors. Signals whose names begin with a slash (/) are active low.

Table 4-9 Descriptions of signals on the RAM expansion connector

Signal name	Connector	Description
+5V_MAIN	Both	5.0 V \pm 5%; 500 mA maximum for each card
+3V_MAIN	User only	3.6 V \pm 5%; 500 mA maximum. Devices that use the +3V supply must be 5 V tolerant.
/CAS(0–3)	Factory only	Column address select signals for the individual bytes in a longword. The signals are assigned to the bytes as follows: / CAS(3) selects PD(24–31) / CAS(2) selects PD(16–23) / CAS(1) selects PD(8–15) / CAS(0) selects PD(0–7)
GND	Both	Chassis and logic ground.
MA(0–11)	Factory only	Multiplexed row and column address to the DRAM devices on the factory-installed RAM card. (See “Address Multiplexing” beginning on page 44.)
PD(0–31)	Both	Bidirectional 32-bit DRAM data bus.
/RAMOE	Both	Output enable signal to the DRAM devices.
/RAMWE	Factory only	Write enable for all banks of DRAM on the factory-installed RAM card.
/RAS(1)	Factory only	Row address select signal. The /RAS(1) signal selects the bank of DRAM on the factory-installed RAM card.
/RCAS(0–3)	User only	Buffered column address select signals for the individual bytes in a longword. The signals are assigned to the bytes as follows: / RCAS(3) selects PD(24–31) / RCAS(2) selects PD(16–23) / RCAS(1) selects PD(8–15) / RCAS(0) selects PD(0–7)
RMA(0–11)	User only	Buffered multiplexed row and column address to the DRAM devices on the user-installed RAM expansion card. (See “Address Multiplexing” beginning on page 44.)

continued

Table 4-9 Descriptions of signals on the RAM expansion connector (continued)

Signal name	Connector	Description
/RRAMOE	User only	Output enable signal to the DRAM devices on the user-installed RAM expansion cards.
/RRAMWE	User only	Buffered write enable for all banks of DRAM on the user-installed RAM expansion cards.
/RRAS(2-7)	User only	Buffered row address select signals for DRAM on the user-installed RAM expansion cards. Table 4-12 and Table 4-13 show how the /RRAS signals select the individual memory banks.

In the table, signals are specified as inputs or outputs with respect to the main logic board that contains the CPU and memory module; for example, an input is driven by the RAM expansion card into the logic board.

Address signals must be stable before the falling edge of /RRAS(n).

Because each address line is connected to every DRAM device, the address signals for the two user-installed RAM cards are buffered on the main logic board. Signals RMA(0-11), /RCAS(0-3), /RRAS(0-3), and /RRAMWE are buffered by 74FCT245 devices and 22 Ω damping resistors.

Address Multiplexing

Signals RMA(0-11) make up a 12-bit multiplexed address bus and can support several different types of DRAM devices.

Depending on their internal design and size, different types of DRAM devices require different row and column address multiplexing. The operation of the multiplexing is determined by the way the address pins on the devices are connected to individual signals on the RMA(0-11) bus and depends on the exact type of DRAM used.

Table 4-10 shows how the signals on the address bus are connected for several types of DRAM devices. The device types are specified by their size and by the number of row and column address bits they require.

Table 4-10 also shows how the signals are multiplexed during the row and column address phases. For each type of DRAM device, the first and second rows show the actual address bits that drive each address pin during row addressing and column addressing, respectively. The third row shows how the device's address pins are connected to the signals on the RMA(0-11) bus.

IMPORTANT

Some types of DRAM devices don't use all 12 bits in the row or column address. The table shows the address bit numbers for those unused bits in italics; bit numbers for the bits that are used are shown in bold. ▲

Table 4-10 Address multiplexing for some typical DRAM devices

Type of DRAM device	Individual signals on DRAM address bus											
	[11]	[10]	[9]	[8]	[7]	[6]	[5]	[4]	[3]	[2]	[1]	[0]
4 M by 1 or 4 M by 4; 11 row bits, 11 column bits												
Row address bits	21	22	20	18	17	16	15	14	13	12	11	10
Column address bits	19	23	21	19	9	8	7	6	5	4	3	2
Device address pins	—	10	9	8	7	6	5	4	3	2	1	0
2 M by 8; 12 row bits, 9 column bits												
Row address bits	21	22	20	18	17	16	15	14	13	12	11	10
Column address bits	19	23	21	19	9	8	7	6	5	4	3	2
Device address pins	11	10	9	8	7	6	5	4	3	2	1	0
2 M by 8; 11 row bits, 10 column bits												
Row address bits	21	22	20	18	17	16	15	14	13	12	11	10
Column address bits	19	23	21	19	9	8	7	6	5	4	3	2
Device address pins	—	10	9	8	7	6	5	4	3	2	1	0
1 M by 4 or 1 M by 16; 11 row bits, 9 column bits												
Row address bits	21	22	20	18	17	16	15	14	13	12	11	10
Column address bits	19	23	21	19	9	8	7	6	5	4	3	2
Device address pins	10	—	9	8	7	6	5	4	3	2	1	0
1 M by 4 or 1 M by 16; 10 row bits, 10 column bits												
Row address bits	21	22	20	18	17	16	15	14	13	12	11	10
Column address bits	19	23	21	19	9	8	7	6	5	4	3	2
Device address pins	—	—	9	8	7	6	5	4	3	2	1	0
512K by 8; 10 row bits, 9 column bits												
Row address bits	21	22	20	18	17	16	15	14	13	12	11	10
Column address bits	19	23	21	19	9	8	7	6	5	4	3	2
Device address pins	—	—	9	8	7	6	5	4	3	2	1	0

Expansion Modules

Note

The address multiplexing scheme used in the PowerBook 1400 computer supports only the types of RAM devices shown in Table 4-10. Other RAM types should not be used. ♦

RAM Banks

The RAM on the user-installed cards is configured in one to three banks, with 2 to 16 MB in each bank. On a card with more than one bank, all banks must be the same size. Table 4-11 shows how the banks can be implemented with standard RAM devices.

Table 4-11 Configurations of RAM banks

Size of bank	Number of devices per bank	Device size (bits)
2 MB	4	512K × 8
4 MB	8	1 M × 4
4 MB	2	1 M × 16
8 MB	4	2 M × 8
16 MB	8	4 M × 4

Because only one bank is active at a time, and because different-sized DRAM devices consume about the same amount of power when active, a card having fewer devices per bank consumes less power than a card having more devices per bank.

Note

The largest possible RAM expansion card contains 48 MB of RAM, and two such cards would provide 96 MB. However, the maximum memory the PowerBook 1400 can support is 64 MB.

RAM Bank Selection

Each user-installed RAM expansion card can have up to three banks of DRAM devices, selected by individual /RRAS signals as shown in Table 4-12 and Table 4-13.

Table 4-12 RAM bank selection

Signal name	Bank number	Bank location
/RAS(0)	0	Main logic board
/RAS(1)	1	Factory-installed RAM expansion card
/RRAS(2)	2	First user-installed RAM expansion card
/RRAS(3)	3	First user-installed RAM expansion card

Expansion Modules

Table 4-12 RAM bank selection (continued)

Signal name	Bank number	Bank location
/RRAS(4)	4	First user-installed RAM expansion card
/RRAS(5)	5	Second user-installed RAM expansion card
/RRAS(6)	6	Second user-installed RAM expansion card
/RRAS(7)	7	Second user-installed RAM expansion card

User-installed RAM expansion cards are interchangeable; that is, any such card can be installed by either plugging it into the connector on the logic board or plugging it into the connector on the top of another card that has already been installed. To make sure that the second card selects the second set of three banks, each card connects the /RRAS(5–7) signals from pins 45, 47, and 53 of the plug on its B side to pins 27, 33, and 35 of the receptacle on its A side, as shown in Table 4-13. By this method, even though both user-installed cards receive their /RRAS signals on pins 27, 33, and 35, the cards occupy different addresses ranges.

Table 4-13 Bank selection signal connections

Pin on plug (B side)	Signal name	Signal function on card	Pin on receptacle (A side)
27	/RRAS(2)	Select first bank of RAM	—
33	/RRAS(3)	Select second bank of RAM	—
35	/RRAS(4)	Select third bank of RAM	—
45	/RRAS(5)	Pass through to pin 27	27
47	/RRAS(6)	Pass through to pin 33	33
53	/RRAS(7)	Pass through to pin 35	35

Note

The system software and memory controller IC make the memory banks contiguous. See “Memory Control” on page 10. ♦

DRAM Device Requirements

The DRAM devices used in a RAM expansion card must meet the following minimum specifications:

- fast page mode
- self-refreshing
- low-power grade
- row access time (t_{RAC}) of 70 ns or less

Expansion Modules

- column access time (t_{CAC}) of 20 ns or less
- page-mode cycle time (t_{PC}) of 50 ns or less

DRAM devices that use the 3 V supply must be 5 V tolerant.

IMPORTANT

Space limitations require devices used on the user-installed RAM expansion cards to have TSOP (thin small outline package) rather than SOP or SOJ packages. ▲

Note

The DRAM refresh operation depends on the state of the computer. When the computer is operating normally, the PBX IC provides refresh signals consisting of 2048 CAS before RAS cycles every 128 ms. When the computer goes into sleep mode, the PBX IC switches the DRAM devices to their self-refresh feature to save power. See also “PBX Memory Controller IC” on page 10. ◆

RAM Expansion Card Electrical Limits

The RAM expansion cards must not exceed the following maximum current limits on the +5V supply:

Active	500 mA (each card)
Standby	24 mA
Self-refresh	6 mA

The capacitive loading on the signal lines must not exceed the following limits:

PD(0–31)	70 pF
/RCAS(0–3)	150 pF
RMA(0–11)	200 pF
/RRAMWE	200 pF
/RRAS(2–7)	80 pF

The address signals for the user-installed RAM card are buffered on the main logic board. Signals RMA(0–11), /RCAS(0–3), /RRAS(2–7), and /RRAMWE are buffered by 74FCT245 devices and 22 Ω damping resistors.

Mechanical Design of the RAM Expansion Cards

The PowerBook 1400 computer accepts two types of RAM expansion cards: one factory-installed card and up to two user-installed cards.

Design of the User-Installed RAM Card

Figure 4-6 shows three views of the user-installable RAM expansion card. Two of these cards can be installed, one above the other, by plugging the second card into the receptacle on the first card.

▲ **WARNING**

Do not exceed the dimensions shown in the drawings. Cards that exceed these specifications may damage the computer. ▲

As Figure 4-6 shows, the maximum component height is the same on both sides of the board: 1.30 mm. To keep within the component height restrictions, the DRAM devices on the user-installed RAM expansion card must be of package type TSOP (thin small outline package) rather than SOP or SOJ.

IMPORTANT

The thickness of the PC board is critical; it must be within a 0.05 mm tolerance of 0.80 mm (0.031 inches). ▲

Figure 4-6 User-installed RAM expansion card

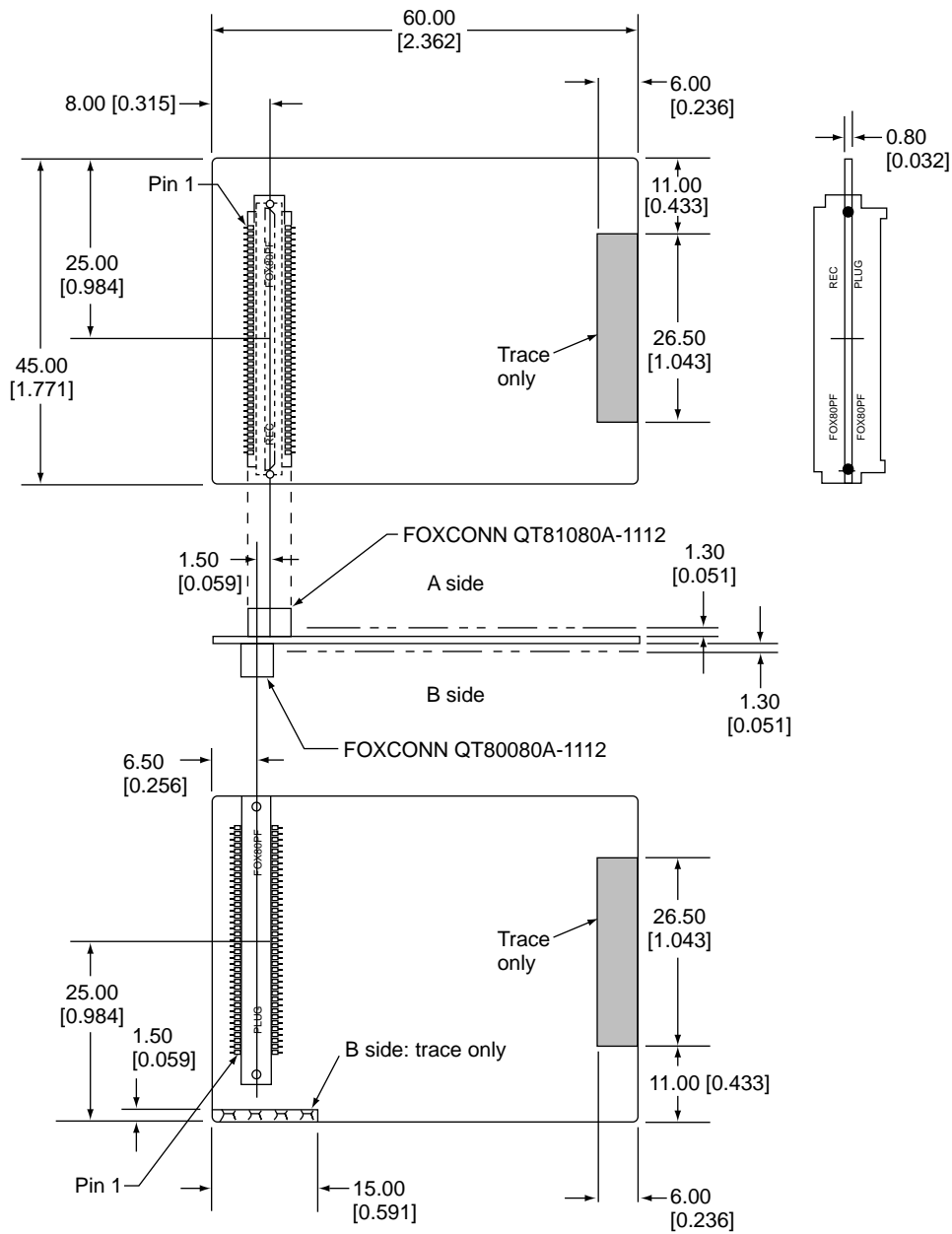

Note: Dimensions are in millimeters [inches].

Design of the Factory-Installed RAM Expansion Card

Figure 4-7 shows the edge view and the connector side (bottom) of the card. Figure 4-8 shows the maximum component height and the restricted areas on the connector side of the card. The maximum component height over the entire top side of the card is 3.70 mm.

Figure 4-7 Factory-installed RAM card

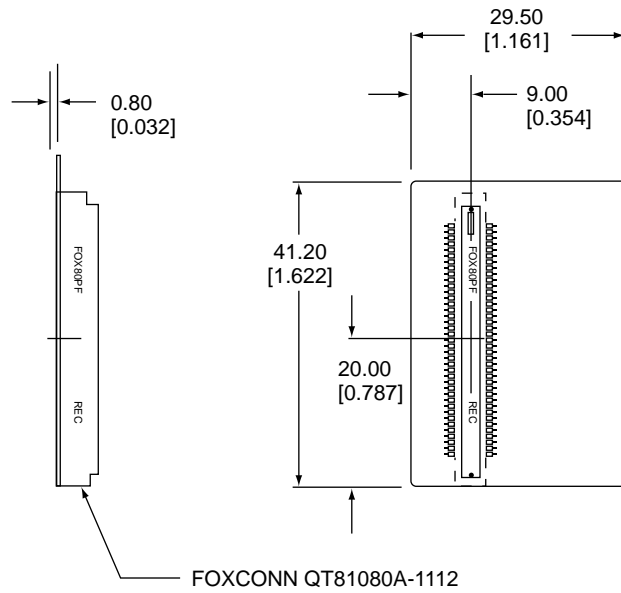

Note: Dimensions are in millimeters [inches].

Figure 4-8 Height limits on the connector side

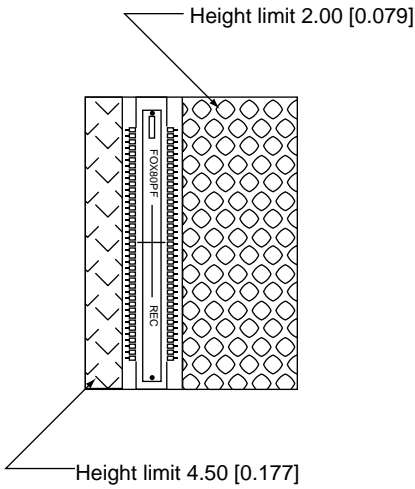

Note: Dimensions are in millimeters [inches].

IMPORTANT

The thickness of the PC board is critical; it must be within a 0.05 mm tolerance of 0.80 mm (0.031 inches). ▲

Expansion Modules

RAM Card Connectors

The connectors on both types of RAM expansion cards are FOXCONN 80-pin fine-pitch (0.8 mm) connectors, manufactured by Hon Hai Precision Industry Co., Ltd., Taipei Taiwan R.O.C. The receptacle, used on the factory-installed card and on the A side of the user-installed card, is part number QT81080A-1112. The plug, on the B side of the user-installed card, is part number QT80080A-1112.

Expansion Card and Connector

The PowerBook 1400 computer accepts an optional expansion card that provides additional functionality. Typical expansion cards include a video monitor card, an Ethernet card, and a modem card. This section describes the expansion card connector and includes a design guide for the expansion card.

Expansion Card Connector

The expansion card is connected to the computer's main logic board by a FOXCONN 80-pin connector. The connector on the card is a surface-mount connector with 0.8 mm pitch, part number QT80080A-1112, manufactured by Hon Hai Precision Industry Co., Ltd., Taipei Taiwan R.O.C.

Signals on the Expansion Card Connector

Table 4-14 shows the pin assignments on the expansion card connector. The table is arranged the same way as the pins on the connector, with pin 1 across from pin 2, and so on.

Table 4-14 Signals on the expansion card connector

Pin number	Signal name	Pin number	Signal name
1	+5V	2	+5V
3	n.c.	4	IO_DATA(8)
5	n.c.	6	GND
7	n.c.	8	IO_DATA(7)
9	IO_DATA(6)	10	IO_DATA(26)
11	IO_DATA(15)	12	IO_DATA(25)
13	IO_DATA(14)	14	IO_DATA(24)
15	IO_DATA(12)	16	IO_DATA(29)

continued

Expansion Modules

Table 4-14 Signals on the expansion card connector (continued)

Pin number	Signal name	Pin number	Signal name
17	IO_DATA(13)	18	IO_DATA(28)
19	IO_DATA(4)	20	IO_DATA(27)
21	GND	22	GND
23	IO_DATA(0)	24	IO_DATA(16)
25	IO_DATA(5)	26	IO_DATA(31)
27	IO_DATA(1)	28	IO_DATA(30)
29	IO_DATA(11)	30	IO_DATA(19)
31	IO_DATA(3)	32	IO_DATA(22)
33	IO_DATA(9)	34	IO_DATA(21)
35	IO_DATA(2)	36	IO_DATA(17)
37	IO_DATA(10)	38	IO_DATA(20)
39	IO_DATA(23)	40	IO_DATA(18)
41	/AS	42	IO_RW
43	/IO_RESET	44	/DSACK(1)
45	+5V	46	+5V
47	SIZ(1)	48	/DSACK(0)
49	SIZ(0)	50	IO_ADDR(0)
51	IO_ADDR(2)	52	IO_ADDR(1)
53	IO_ADDR(5)	54	IO_ADDR(3)
55	IO_ADDR(17)	56	IO_ADDR(4)
57	IO_ADDR(19)	58	IO_ADDR(7)
59	IO_ADDR(15)	60	IO_ADDR(6)
61	IO_ADDR(21)	62	IO_ADDR(10)
63	IO_ADDR(22)	64	IO_ADDR(12)
65	IO_ADDR(23)	66	IO_ADDR(13)
67	IO_ADDR(20)	68	IO_ADDR(11)
69	/KEY_CS	70	IO_ADDR(14)
71	/VID_IRQ	72	IO_ADDR(9)
73	VID_CLK	74	IO_ADDR(16)
75	+5V	76	IO_ADDR(8)
77	BUF_IOCLK	78	IO_ADDR(18)
79	GND	80	GND

Expansion Modules

Table 4-15 gives descriptions of the signals on the expansion card connector.

Table 4-15 Descriptions of the signals on the expansion card connector

Signal name	Description
/AS	Address strobe (68030 bus)
BUF_IOCLK	25 MHz I/O clock
/DSACK(1-0)	Bus data acknowledge (68030 bus)
/EXT_VID_CS	/CS for locations \$FDXX XXXX
IO_ADDR(23-0)	Address bus (68030 bus)
IO_DATA(31-0)	Data bus (68030 bus)
IO_RESET	Device reset; active low
IO_RW	Read/write (68030 bus)
/KEY_CS	/CS for locations \$FEXX XXXX; reserved
SIZ(1-0)	Size of video RAM
VID_CLK	16 MHz video clock
/VID_IRQ	Video interrupt

Expansion Card Mechanical Design

Figure 4-9 is a plan view of the component side of the card showing the location of the attachment holes for the video connector. Figure 4-10 is a plan view of the trace side of the card showing the dimensions of the card and the locations of the connectors.

Expansion cards with other functions must have their external connectors in the location shown for the video connector.

Expansion Modules

Figure 4-9 Component side of the expansion card

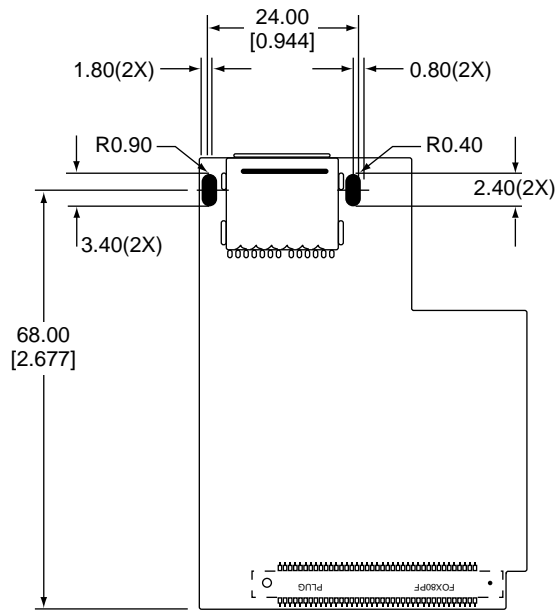

Note: Dimensions are in millimeters [inches].

Figure 4-10 Trace side of the expansion card

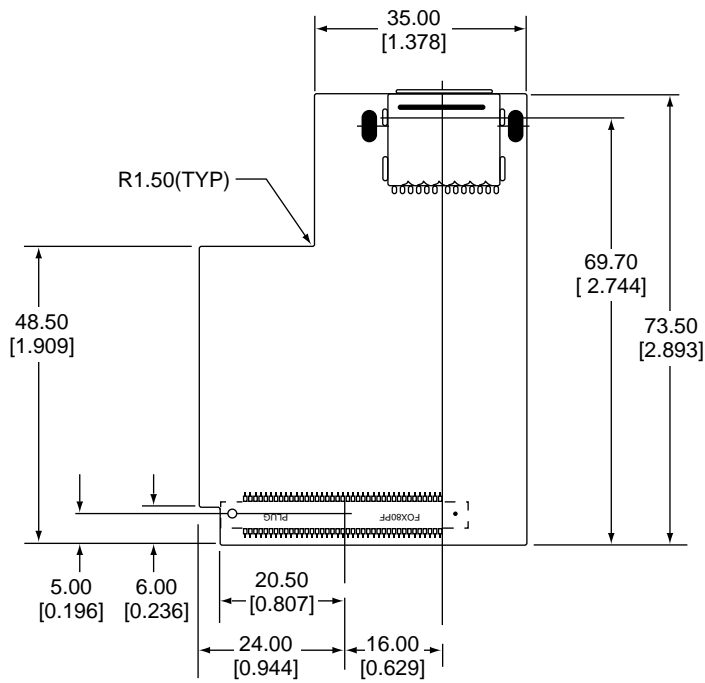

Note: Dimensions are in millimeters [inches].

Expansion Modules

Figure 4-11 and Figure 4-12 show the height restrictions on the component side and the trace side of the card, respectively.

Figure 4-11 Height restrictions on the component side

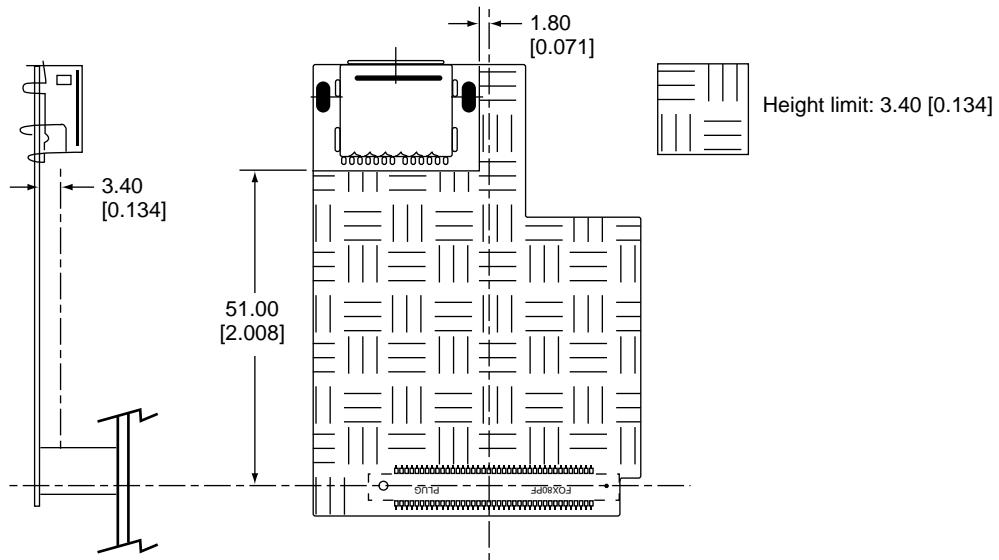

Note: Dimensions are in millimeters [inches].

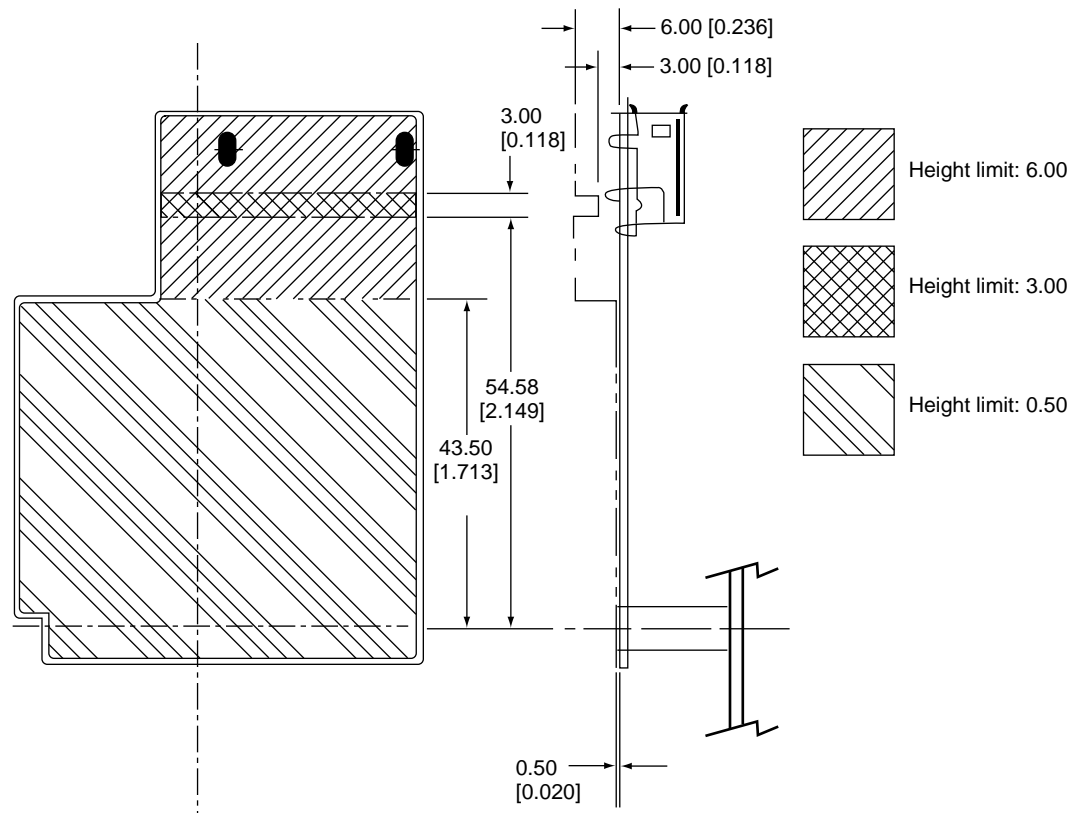
Figure 4-12 Height restrictions on the trace side

Note: Dimensions are in millimeters [inches].

IMPORTANT

The expansion card is mounted upside down in the computer; that is, the component side is on the bottom and the trace side is on the top. ▲

The thickness of the expansion card's PC board is 0.80 mm (0.031 inches).

PC Card Slot

The PowerBook 1400 computer has a PC card slot that can accept two type II PC cards or one type III PC card. This section summarizes the features and specifications of the PC card slots. For complete specifications and descriptions of the software interfaces, developers should consult *PC Card Expansion for PowerBook Computers*.

PC Card Features

The PC card slot supports two types of PC cards: mass storage cards such as SRAM and ATA drives (both rotating hard disk and flash media) and I/O cards such as modems, network cards, and video cards. The Macintosh desktop metaphor includes the concept of storage device representation, so it already supports mass storage cards. Apple Computer has extended the metaphor to include I/O cards as well.

The user can insert or remove a PC card while the computer is operating. The user can eject a PC card either by clicking the Eject option in a Finder menu or by dragging the card's icon to the Trash.

PowerBook computers with PC card slots currently support PC card ejection by software command. Software ejection is controlled by Card Services and allows Card Services to eject a PC card after notifying all clients of the card that its ejection is about to occur. If clients are using resources on the card, the clients have the option of refusing the request and alerting users to the reasons why an ejection can't take place.

Support for I/O-oriented PC cards is provided through a Macintosh Finder extension that is a client of the Card Services software. The Finder extension is responsible for maintaining card icons on the desktop, providing card information in Get Info windows, and ejecting cards when they're dragged to the Trash. The Finder extension also helps a client provide custom features such as icons, card names, card types, and help messages.

Summary Specifications

The PC card slot in the PowerBook 1400 computer contains two standard PC card sockets. Each socket accepts either a type I or type II card. The PC card slot also accepts one type III card, which occupies both sockets.

The mechanical and electrical characteristics of the PC card slot conform to the specifications given in the *PCMCIA PC Card Standard*, Release 2.1.

The sockets support 16-bit PC cards. Each socket is 5-volt keyed and supports either a memory PC card or an I/O PC card.

Access Windows

Each socket supports two access windows in the computer's address space:

- one attribute memory or common memory window
- one I/O window

The only valid window combinations are the following:

- one attribute memory window
- one common memory window
- one common memory window and one I/O window

Expansion Modules

Each window has a 64 MB address space. The window address spaces could be implemented as 8 MB pages in some systems. The PC card interface has the ability to map the entire PC card's memory space into the host system's memory window.

Each window has its own independent access timing register.

Data Access

Each socket supports both byte and word data access in both memory and I/O modes. The IOIS16 signal determines whether word access is single 16-bit access or two 8-bit accesses. The byte-swapping option is always big-endian mode.

The CE1 and CE2 signals determine the type of data bus access, as follows:

- word access: CE1=L, CE2=L
- even bus access: CE1=L, CE2=H
- odd bus access (not allowed): CE1=H, CE2=L

Signal Definitions

Certain signals on the PC card sockets are defined as follows:

- BVD1, BVD2: battery voltage signals (status and interrupt)
- WP: write protect (status and interrupt)
- RDY/BSY: ready/busy signal (status and interrupt)
- WAIT: used to delay access (maximum asserted time is 10 μ S)
- IRQ: interrupt request, level mode only (pulse mode is not supported)
- SPKR: speaker (digital audio output)
- STSCHG/RI: status change and ring indicator (wake-up mode)
- INPACK: not supported

Power

The PC card sockets provide power as follows:

- Vcc: Programmed as either 0 V or 5 V.
- Vpp1, Vpp2: Programmed as either 5 V or 12 V.

Vpp1 and Vpp2 cannot be programmed independently.

The maximum current from the Vcc pin is 600 mA. The maximum current from each Vpp1 or Vpp2 pin is 30 mA. The maximum current from all Vpp pins is 120 mA.

The sockets support a low-powered sleep mode.

Controller Interrupts

There is a single interrupt for both sockets. The interrupt is a combination of the status change signal and the PC card's interrupt request signal.

Software Features

Software Features

This chapter describes the new features of the software for the PowerBook 1400 computer. It describes the built-in ROM and the system software that resides on the hard disk. A separate section describes Open Transport, Apple Computer's new standard for Macintosh networking and communications, now available on a PowerBook model for the first time.

ROM Software

The ROM software in the PowerBook 1400 computer is based on the ROM used in the Macintosh PowerBook 5300 computer, with changes to support new features. Some of the features this ROM supports include the following:

- new machine identification
- support for larger flat panel displays

Machine Identification

The ROM includes new tables and code for identifying the machine.

Applications can find out which computer they are running on by using the Gestalt Manager. The `gestaltMachineType` value returned by the PowerBook 1400 computer is 311 (hexadecimal \$137). *Inside Macintosh: Overview* describes the Gestalt Manager and tells how to use the `gestaltMachineType` value to obtain the machine name string.

Larger Flat Panel Displays

The ROM has been modified to support the 600-by-800 pixel (SVGA) flat panel displays. The PowerBook 1400 computer uses the same video controller IC used in the Macintosh PowerBook 5300. That IC, called ECSC, supports 1 MB of video RAM.

System Software

The PowerBook 1400 computer is shipped with a modified version of Mac OS version 7.5.3. This version of the Mac OS includes the functionality of Mac OS version 7.5.2 used in the Macintosh PowerBook 5300 along with several bug fixes and enhancements.

Note

The reference release of Mac OS version 7.5.3. will not run on the PowerBook 1400 computer. The version of the Mac OS shipped with the PowerBook 1400 computer will not run on other Macintosh models. ♦

Modified Software Components

Version 7.5.3 of the system software includes several changed components, listed here along with some of the changes.

Apple Guide

The new version 2.0 of Apple Guide has the following changes:

- It runs in native mode on Macintosh computers equipped with PowerPC microprocessors.
- It corrects several bugs, including one that formerly caused problems displaying coach marks in modal dialog boxes.
- It now defaults to U.S. ASCII sorting only if the current script is Roman and the current language is English.
- It now operates properly even when additions are present that do not apply to the current configuration of the computer.
- It has a Gestalt selector 'ag_v' that returns the current version of Apple Guide.

Apple Menu Options

The new version 1.1 of Apple Menu Options has the following changes:

- It corrects a few bugs, including one that formerly caused the computer to hang if a locked alias was present in the Recent Documents, Recent Applications, or Recent Servers folder.
- It provides appropriate sorting order—not U.S. ASCII—for the Scandinavian countries and for countries using modified Roman scripts.

CloseView

CloseView has the following changes:

- It corrects several bugs, including one that formerly deactivated CloseView if the user changed the pixel depth in the Monitors control panel.
- It no longer uses key combinations that are also used by the Finder. The new key combinations are as follows:
 - Command-Option-K turns CloseView on and off.
 - Command-Option-+ (plus sign) increases magnification.
 - Command-Option-- (minus sign) decreases magnification.

Enabler

The enabler for the PowerBook 1400 computer provides Fkey functions formerly found in the Assistant Toolbox extension:

- Fkey for selecting sleep mode: Command-Shift-0 (zero)
- Fkey for selecting hard disk spin down: Control-Command-Shift-0 (zero)

Software Features

- Persistent RAM disk

File Sharing

The new File Sharing version 7.5.2 has the following changes:

- It supports shared files on removable disks appropriately when the disks are inserted and removed.
- It corrects a few bugs, including one that formerly caused certain files not to be copied.

Finder

The Finder has the following changes:

- It maintains comments in Get Info windows when it rebuilds the desktop.
- It accommodates longer names in Finder windows.
- It achieves better performance by flushing the processor's cache more intelligently.
- It shows icons as translucent instead of as outlines while they are being dragged.

Find File

Find File has the following changes:

- It runs in native mode on Macintosh computers equipped with PowerPC microprocessors.
- It searches faster in 2-byte languages.
- It corrects several bugs, including one that formerly caused the program to crash if the user clicked the Stop button while the program was sorting.

General Controls Control Panel

The General Controls control panel has the following changes:

- It corrects several bugs, including former conflicts with several third-party products.
- It restores a default folder behavior from before System 7.5. After the user selects a checkbox named "Folder that is set by the application," double-clicking to open a document will cause the default folder to be set to the folder containing the document.

Memory Control Panel

The Memory control panel has the following changes:

- It corrects several bugs, including one that formerly occurred when the user changed the size of the RAM disk while file sharing was on.
- It uses a larger default setting for the disk cache, equal to 32 KB for each megabyte of physical RAM installed.
- It displays the message "Will be off after restart" when the user turns virtual memory off. The computer must be restarted for virtual memory to become inactive.

Software Features

Monitors & Sound

The Monitors & Sound control panel on the PowerBook 1400 computer is new to the PowerBook computers. It combines the functions formerly provided by three separate control panels: Monitors, Sound, and PowerBook Display.

Native Resource Manager

The version of the Native Resource Manager in the PowerBook 1400 computer is an improved version of the one in the system software that came with the Macintosh PowerBook 5300.

Open Transport

Version 1.1 of Open Transport is a new implementation for use on all Macintosh models that have 68030, 68040, or PowerPC microprocessors. For more information, see “Open Transport” beginning on page 66.

Note

Open Transport uses the TCP/IP control panel and is not compatible with MacTCP. The user can select either Open Transport or AppleTalk with the Network Software Selector control panel; with AppleTalk selected, the system uses MacTCP. ♦

SimpleText

The new version 1.3.1 of SimpleText supports QuickDraw 3D.

Consolidation of Files

Several files found in earlier versions of the system have been renamed or incorporated into other files. The following files formerly found in System 7.5 no longer appear:

- 040 VM Update
- 601 Processor Card Enabler
- 630 SCSI Update
- 7.5.2 Printing Fix
- Apple Multimedia Tuner
- CFM Updater
- Color Classic Update
- Display Enabler 2.0
- EM Sound Update
- Finder Update
- LaserWriter 8.0

Software Features

- MathLib
- Mount IDE Drive
- PowerBook 150 Update
- PowerBook 5300 Enabler
- PowerBook 5300/190 Enabler
- PowerPC Enabler
- PowerPC Finder Update
- SCSI Manager
- SCSI Manager 4.3
- SerialDMA
- Serial Update 406
- Sound Manager
- System Enabler 406
- ThreadsLib
- Workgroup Server Enabler

Open Transport

Open Transport is the new communications and networking architecture that will become the standard for Macintosh networking and communications.

Open Transport provides a mechanism for communications applications to operate independently from underlying networks such as AppleTalk, TCP, or IPX. Open Transport provides a code base and architecture that support network stacks while eliminating many of the interrupt latency problems associated with AppleTalk.

Note

Open Transport runs native on the PowerPC microprocessors. ♦

Open Transport has two major aspects: the client interfaces and the environment for developing protocols and communications modules. The Open Transport client interfaces are a superset of the XTI interface from X/Open, a consortium of UNIX[®] vendors. XTI is a superset of TLI, a UNIX standard interface. By using the Open Transport interfaces, applications (called *clients*) can operate independently of the transport layer.

The environment for developing protocols and communications modules for Open Transport also uses industry standards. These standards are the UNIX standard Streams, and two other standards, Transport Provider Interface (TPI) and Data Link Provider Interface (DLPI).

Open Transport does not use the conventional .ENET-style drivers; instead it uses Streams-based DLPI drivers that are more appropriate for use with PCI devices. In

Software Features

addition to being consistent with industry standards, Streams-based DLPI drivers provide higher performance than .ENET-style drivers.

Apple Computer's Open Transport software includes new stack implementations for AppleTalk and MacTCP. Apple expects that third parties will provide implementations of DECnet™, IPX, and other network protocols.

The Open Transport implementation of TCP/IP is a replacement for MacTCP. It is designed for use under the Open Transport software interface.

New Features of Open Transport

The new features of Open Transport include

- a new API
- dynamic loading and shared code
- an optional static node number (AppleTalk)
- an optional NBP-to-catalog server (AppleTalk)
- IP multicasting (MacTCP)
- dynamic retransmission timers (MacTCP)

Compatibility

Open Transport is compatible with existing AppleTalk networks and supports existing .ENET clients such as Soft Windows™ and DECnet. On the PCI-based Power Macintosh computers, this .ENET compatibility is provided by a module that maps .ENET calls to the corresponding DLPI calls.

Open Transport provides compatibility with Power Macintosh computers by means of the following features:

- environment options
- 680x0-based APIs and stacks that run in emulation mode
- Open Transport APIs and stacks that run in native mode
- API compatibility glue that runs in mixed mode
- 680x0-based applications that can use parameter-block APIs with Open Transport stacks
- 680x0-based applications that can use Open Transport APIs and stacks
- native applications that can use parameter block APIs with 680x0-based stacks
- native applications that can use parameter block APIs with Open Transport stacks

Glossary

680x0 code Instructions that can run on a PowerPC microprocessor only by means of an emulator. See also **native code**.

ADB See **Apple Desktop Bus**.

API See **application programming interface**.

Apple Desktop Bus (ADB) An asynchronous bus used to connect relatively slow user-input devices to Apple computers.

Apple Developer Catalog (ADC) Apple Computer's worldwide direct distribution channel for Apple and third-party development tools and documentation products.

Apple SuperDrive Apple Computer's disk drive for high-density floppy disks.

AppleTalk Apple Computer's local area networking protocol.

application programming interface (API) The calls and data structures that allow application software to use the features of the operating system.

Baboon The custom IC that controls a floppy disk drive or an IDE hard disk drive in the expansion bay.

big endian Data formatting in which each field is addressed by referring to its most significant byte. See also **little endian**.

codec A digital encoder and decoder.

color depth The number of bits required to encode the color of each pixel in a display.

DAC See **digital-to-analog converter**.

data burst Multiple longwords of data sent over a bus in a single, uninterrupted stream.

data cache In a PowerPC microprocessor, the internal registers that hold data being processed.

digital-to-analog converter (DAC) A device that produces an analog electrical signal in response to digital data.

direct memory access (DMA) A process for transferring data rapidly into or out of RAM without passing it through a processor or buffer.

DLPI Data Link Provider Interface, the standard networking model used in Open Transport.

DMA See **direct memory access**.

DRAM See **dynamic random-access memory**.

DR Emulator The Dynamic Recompilation Emulator, an improved 680x0-code emulator for the PowerPC microprocessor.

dynamic random-access memory (DRAM) Random-access memory in which each storage address must be periodically interrogated (or refreshed) to maintain its value.

ECSC Enhanced color support chip, the custom IC that provides the data and control interface to the flat panel display.

Ethernet A high-speed local area network technology that includes both cable standards and a series of communications protocols.

input/output (I/O) Parts of a computer system that transfer data to or from peripheral devices.

I/O See **input/output**.

little endian Data formatting in which each field is addressed by referring to its least significant byte. See also **big endian**.

LocalTalk The cable terminations and other hardware that Apple supplies for local area networking from Macintosh serial ports.

mini-DIN An international standard form of cable connector for peripheral devices.

native code Instructions that run directly on a PowerPC microprocessor. See also **680x0 code**.

nonvolatile RAM RAM that retains its contents even when the computer is turned off; also known as *parameter RAM*.

NuBus A bus architecture in Apple computers that supports plug-in expansion cards.

PBX The custom IC that provides the interface between the PowerPC 603 bus and the I/O bus in the latest Macintosh PowerBook computers.

PC card An expansion card that conforms to the PCMCIA standard.

PC Card Manager The part of the Mac OS that supports PC cards in PowerBook computers.

PCMCIA standard An industry standard for computer expansion cards.

pixel Contraction of *picture element*; the smallest dot that can be drawn on a display.

PowerPC Trade name for a family of RISC microprocessors. The PowerPC 601, 603, and 604 microprocessors are used in Power Macintosh computers.

reduced instruction set computing (RISC) A technology of microprocessor design in which all machine instructions are uniformly formatted and are processed through the same steps.

RISC See **reduced instruction set computing**.

SCC See **Serial Communications Controller**.

SCSI See **Small Computer System Interface**.

Serial Communications Controller (SCC)
Circuitry on the Combo IC that provides an interface to the serial data ports.

SIMM See **Single Inline Memory Module**.

Single Inline Memory Module (SIMM) A plug-in card for memory expansion, containing several RAM ICs and their interconnections.

Small Computer System Interface (SCSI)
An industry standard parallel bus protocol for connecting computers to peripheral devices such as hard disk drives.

socket The hardware receptacle that a PC card is inserted into.

Socket Services The layer of software that is responsible for communication between Card Services and the socket controller hardware.

TREX The custom IC that controls the PC card expansion slot.

Versatile Interface Adapter (VIA) The interface for system interrupts that is standard on most Apple computers.

VIA See **Versatile Interface Adapter**.

video RAM (VRAM) Random-access memory used to store both static graphics and video frames.

VRAM See **video RAM**.

Whitney The custom IC that provides the interface between the I/O bus and many of the I/O devices in the latest Macintosh PowerBook computers.

Index

Numerals

68HC05 microprocessor 12

A

AC adapter 6
access to internal components 21
active-matrix display 22
ADB (Apple Desktop Bus) port 24
ADB connector 25
appearance 4
Apple Guide 63
Apple Menu Options 63
AppleTalk stack for Open Transport 67
ATA interface 16

B

Baboon custom IC 13
block diagram 9

C

caps lock key 21
CloseView 63
Combo custom IC 12
configurations 5
connectors
 ADB 25
 expansion bay 34
 CD-ROM and hard disk 36
 floppy disk 34
 hard disk 18
 RAM expansion 41, 43
 RAM expansion card 52
 SCSI 24
 serial port 23
custom ICs
 Baboon 13
 Combo 12
 ECSC 12
 PBX 8, 10

Singer 12, 26
TREX 13
Whitney 11

D

display controller IC 12
displays
 active matrix 22
 backlighting 22
 DualScan 22
 flat panel types 22
 FSTN 22
 NuBus card emulation 22
 number of colors 22
 passive matrix 22
 supertwist 22
 TFT 22
DLPI drivers compared with .ENET drivers 67
DRAM devices for RAM expansion 47
DualScan display 22

E

ECSC custom IC 12
.ENET drivers compared with DLPI drivers 67
expansion bay 30–40
 installation of a module 39
 module for CD-ROM 32
 module for floppy disk 30
 module for hard disk 32
expansion bay connectors 34–39
 for CD-ROM and hard disk 36
 for floppy disk 34
expansion bay controller IC 13
expansion card 52–57
 component height restrictions 56, 57
 connector 52–54
 signal assignments 52
 signal descriptions 54
 dimensions 55
 location of connectors 54
 mechanical design 54–57

F

features, new 2
 features, unchanged 3
 File Sharing 64
 Finder 64
 Find File 64
 flat panel display 22

G

General Controls control panel 64
 gestaltMachineType value 62

H

hard disk 16
 dimensions 16
 IDE data bus 20
 hard disk capacity 5
 hard disk connector 18
 signal assignments on 18
 signal descriptions 19
 HDI-30 connector 24

I, J

icons, translucent 64
 IDE disk interface 16
 IDE hard disk 16
 connector 18
 data bus 20
 dimensions 16
 signals 19
 identifying the computer 62
 infrared (IR) link 25
 I/O bus 8
 I/O ports
 SCSI 23
 serial 23

K

keyboard 21
 caps lock key 21
 ISO layout 21
 removing 21

U.S. layout 21

M

Mac OS 7.5.3 62
 modified components of 63
 MacTCP stack for Open Transport 67
 main processor 8
 memory controller IC 10
 Memory control panel 64
 Monitors & Sound control panel 65

N

Native Resource Manager 65
 Network Software Selector control panel 65
 new features 2

O

Open Transport 65, 66–67
 AppleTalk stack for 67
 client interface 66
 development environment 66
 DLPI drivers 67
 features of 67
 MacTCP stack for 67

P

PBX custom IC 10
 as bus bridge 10
 PC cards 58
 features 58
 Finder extension for 58
 software eject 58
 PC card slots 57–60
 access windows 58
 data access modes 59
 power 59
 signal definitions 59
 specifications 58–60
 peripheral devices 6
 peripheral support IC 11
 pointing device 20
 Power Manager IC 12
 PowerPC 603e microprocessor 8
 processor bus 8

clock speed 8
processor clock speed 8

Q

QuickDraw 3D 65

R

RAM

contiguous banks of 10
expansion 46–52
 addressing 44
 bank selection 46, 47
 DRAM devices 47
 RAM banks 46
 signals 41, 43
size of 5

RAM expansion cards 46–52
 bank selection on 46, 47
 connector 52
 DRAM devices 47
 electrical limits 48
 factory installed 41, 50–51
 dimensions 51
 mechanical design of 49–52
 RAM banks 46
 user installed 41, 49
 dimensions 50

reference documents x

ROM

address range 10
for larger flat panels 62
implementation of 10
software features 62

S

SCC (serial communications controller) 12
SCSI controller 12
SCSI port 23
 connector 24
serial port 23
SimpleText 65
Singer custom IC 12, 26
sound
 input sources 26
 built-in microphone 26
 CD-ROM drive 27

PCMCIA slot 27
 sound input jack 26
 output devices 27
sound circuits 26
 characteristics 27
sound IC 12, 26
sound sample rates 26
sound specifications 26
Streams network protocol 67
Supertwist display 22
system software version 7.5.3 62

T

TFT display 22
trackball 20
trackpad 20
TREX custom IC 13

U, V

unchanged features 3

W

Whitney custom IC 11

X, Y, Z

XTI interface, with Open Transport 66

This Apple manual was written, edited, and composed on a desktop publishing system using Apple Macintosh computers and FrameMaker software. Proof pages were created on an Apple LaserWriter Pro printer. Final pages were created on a Docutek. Line art was created using Adobe™ Illustrator and Adobe Photoshop. PostScript™, the page-description language for the LaserWriter, was developed by Adobe Systems Incorporated.

Text type is Palatino® and display type is Helvetica®. Bullets are ITC Zapf Dingbats®. Some elements, such as program listings, are set in Apple Courier.

WRITER

Allen Watson III

DEVELOPMENTAL EDITORS

Wendy Krafft, Beverly McGuire

PRODUCTION EDITOR

JoAnne Smith

ILLUSTRATOR

Sandee Karr

Special thanks to Rodney Amen, David Buuck, Godfrey DiGiorgi, Garet Igarashi, John Kelley, Doug MacMillan, and Richard Mehler